

# B-TYPE CAM SWITCH



Rotating Operation  
(B-type)



Rotating Operation  
(JB-type)

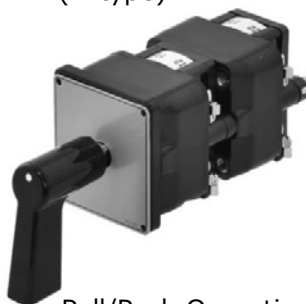

Pull/Push Operation  
(B-type)



Key Handle Operation

## INDEX

Structure and Features	A-62
Compliance Standard	A-63
Rated Values and General Characteristics	A-63
Rated Working Voltage and Current	A-64
Operational Instructions	A-65
How to Choose Type	A-66
Operation Method	A-67
Contact Type	A-71
Terminal Cover	A-72
Handle Type	A-72
Name Plate Stand	A-74
Name Plate Type	A-74
Name Plate Letters	A-74
Indicator	A-78
Main Contact Diagram List	A-79
Order Method of Customized Contact Diagram	A-99
Precautions on Ordering Customized Contact Diagram	A-99
Max. Number of Units & Max. Number of Contacts	A-100
Single Part Items	A-104
Outline Drawing	A-108
Handle Mounted Dimensions	A-111
Mounting Hole Dimension and Assembly Method	A-112
Technical Reference	A-113
Order Sheet	A-114

# Structure and Features

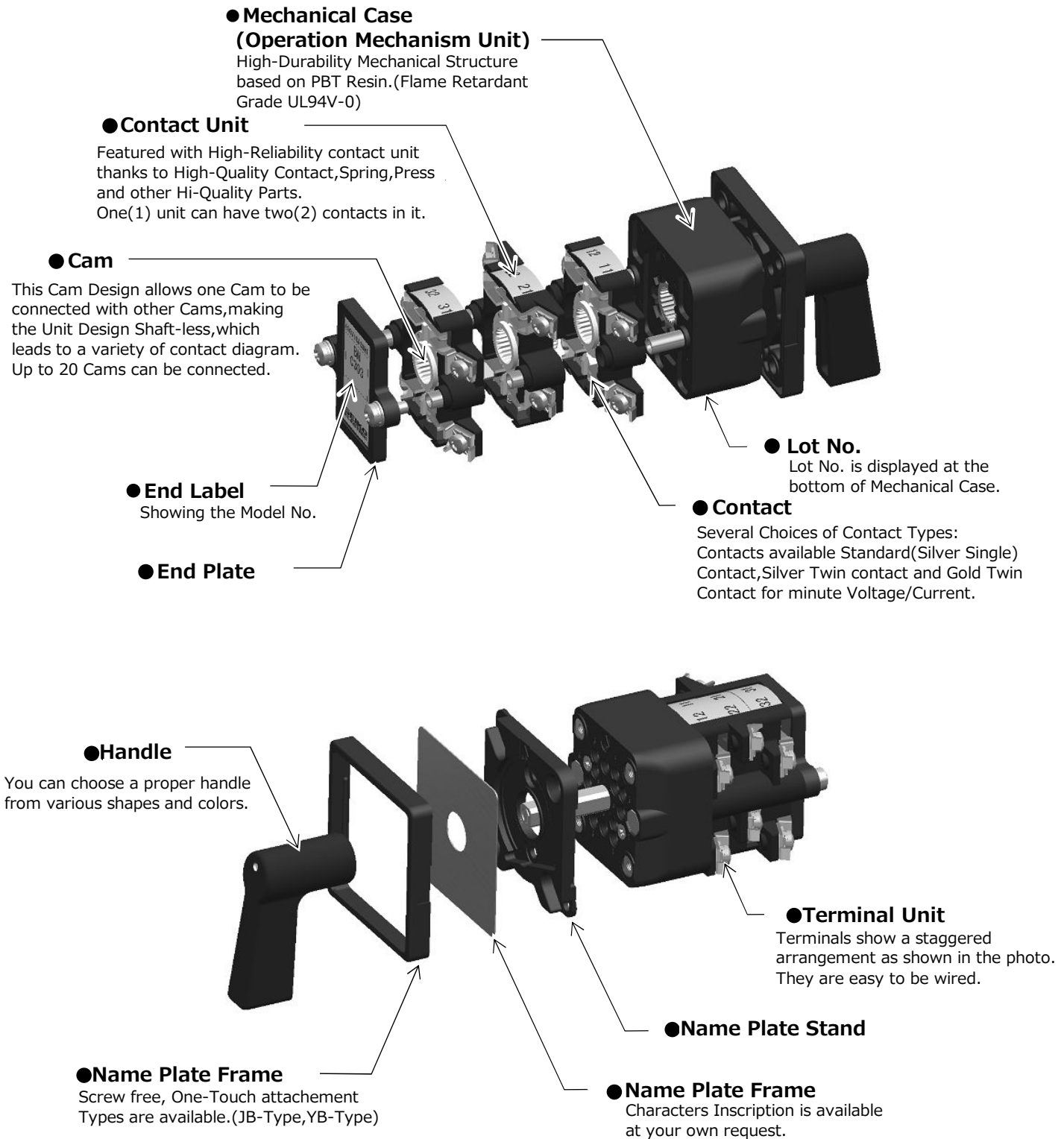

## Compliance Standards

NECA C 4520: General Clauses on Control Switch

NECA C 4522: General Clauses on Control Cam Switch

JIS C 8201-5-1: Low-Voltage Switch Unit and Control Unit - Chapter No.5  
Control Circuit and Switch Element  
-Part 1:Electrical Equipment Control Circuit.

JIS C 0920: General Clauses on Water-Proof Test on Electric Equipment and Wiring Materials.  
IP40 (Panel Surface)

## Rated Values and General Characteristics

※ See page A-71 for explanation about Twin-Contact.

Specification Item	Single Contact(Standard)	Twin Contact ※	
	Silver Contact	Silver Contact(V-Type)	Gold Contact(G-Type)
Rated Insulation Voltage	600V		
Rated Flowing Current	10A	5A	1A
Contact Resistance	100MΩ or up (500V Megger)		
Contact Resistance(Initial Value)	50mΩ or less	20mΩ or less	15mΩ or less
Temperature Rise	Contact	65°C or under	
	Terminal	50°C or under	
Impact Resistance	50G		
Vibration Resistance	2G		
Storage Temperature Range	-40°C~+70°C (but,Shall never cause freezing.)		
Operating Temperature Range	-20°C~+60°C (but,Shall never cause freezing.)		
Operating Humidity Range	45%~85%Rh (but,No dewdrops.)		
Withstand Voltage	AC 2,500V / One (1) Minute		
Impulse-Withstand Voltage	±7,000V (1.2/50μs) / Three (3) Times		
Minimum Operating Voltage and Current(Its ambient circumstances must be good.)	24V 50mA (1.2VA)	5V 10mA (0.05VA)	1V 1mA
Overcurrent Resistance	200A 2 seconds	100A 2seconds	20A 2 seconds
Switching ON/OFF Frequency	1,200 times / hour		
Switching ON/OFF Speed	2πrad/second		
Mechanical Durability	1 million times	300,000 times	
Electrical Durability	AC	100,000 times	
	DC	100,000 times	

## Rated Working Voltage and Current(Beaking Performance)

Rated Working Voltage (V)	DC (Time constant:25ms)						AC (Power Factor:0.4)					
	Rated Working Current (A)						Rated Working Current (A)					
	Resistance Load			Inductive Load			Resistance Load			Inductive Load		
	Standard	V-Type	G-Type	Standard	V-Type	G-Type	Standard	V-Type	G-Type	Standard	V-Type	G-Type
24	10	5	0.15	6	5	0.10	10	—	0.35	—	—	0.25
48	6	5	0.10	4	3	0.05	10	—	0.16	—	—	0.11
110	2.5	2.5	0.055	1.5	1.5	0.025	10	5	0.1	6.5	6.5	0.07
220	0.8	—	—	0.5	—	—	7.5	5	—	4.5	4.5	—
440	—	—	—	—	—	—	3	3	—	2	2	—

Rated Working Voltage (V)	DC (Time constant:25ms)			
	Rated Working Current (A)			
	2-Contacts Series Resistance Load		2-Contacts Parallel Resistance Load	
	Standard	V-Type	Standard	V-Type
24	28	5	20	5
48	22	5	13	5
110	9	5	4.5	4.5
220	2.7	—	1.4	—

# Operational Instructions

## Instruction on Rotating Operation

Operation Method	Descriptions
Manual Return(Notch)	The handle stays at the specified position even after detouching the hand from the handle.
Spring Return	The handle returns automatically to the origin from specified position. (Limit is set at the point of origin.)
Manual & Spring Return (Hybrid)	Composite operation based on Manual and Spring Return Methods.
Spring Return with Position-Sensing(Click)	In this method,you can feel every position at which the handle is set during your operation.

## Operational Position Code

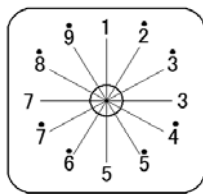

30° Notch

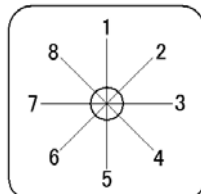

45° Notch

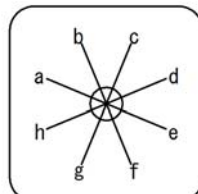

45° Notch  
(Separation from  
the center at 22.5°)

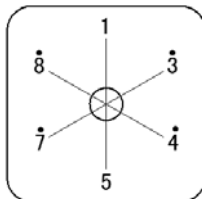

60° Notch

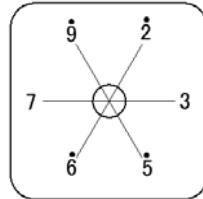

60° Notch  
(Separation from  
the center at 30°)

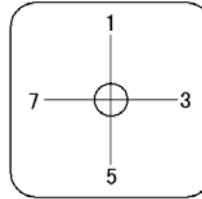

90° Notch

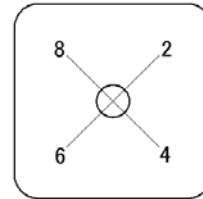

90° Notch  
(Separation from  
the center at 45°)

## Manufacturable Operational Angle

Remarks : ○⇒Manufacturable    △⇒Consultation needed    ×⇒Non-Manufacturable

Operation Method	Notch Angle						
	30°	45°	45° (Separation from the center at 22.5°)	60°	60° (Separation from the center at 30°)	90°	90° (Separation from the center at 45°)
Manual Return (Max. Operational Angle:360°)	○	○	○	○	○	○	○
Spring Return (Max. Operational Angle:90° on single side)	○	○	×	○	×	△	○
Manual & Spring Return Hybrid (Max. Operational Angle:90° on single side)	×	○	×	×	×	×	×
Spring Return with Position-Sensing(Click)	○	○	×	×	×	×	×

# How to Choose Type

**B N - C201 - G0 - C - PK K - N - 0 (W)**

① Basic Type  
② Operational Method  
③ Contact Diagram Code  
④ Contact Type

⑤ Terminal Cover  
⑥ Handle Type  
⑦ NP Stand  
⑧ NP Type  
⑨ NP Letter  
⑩ Indicator

## ① Basic Type

This shows NP shape & attachment type.  
Choose your desired one from the list below.

Code	Spec.
<b>B</b>	Screwing Type 
<b>AB</b>	Screwing Type(Large NP) 
<b>JB</b>	One-Touch Attachment Type) 
<b>YB</b>	One-Touch Attachment Type) 

## ② Operational Method(See A67~A-70 for Details)

Choose your desired Operation Method.

## ③ Contact Diagram Code(See A79~A-98 for Details)

Choose your desired Contact Diagram from the List of Contact Diagram.

Fill your desired Contact Diagram specifications on the order sheet on A-115~A-117 for submission to us.

(In case of Made to order Contact Diagram)  
Pls specify your order by writing [No. of Unit+X] as follows;

For Example : In case of 3 units ... 3X  
In case of 5 units ... 5X

## ④ Contact Type(See A71 for Details)

Choose your desired contact the choices below.  
Standard(Silver Single) / Silver Twin Contact / Gold Twin Contact

## ⑤ Terminal Cover(See A-72 for Details)

Choose whether Terminal Cover is required or not.

## ⑥ Handle Type(See A-72~A-73 for Details)

Choose your desired Handle Type and Color.

## ⑦ Name Plate Stand(See A-74 for Details)

Choose your desired color of NP stand.

## ⑧ Name Plate Type(See A-74 for Details)

Choose your desired type(materials) of Name Plate.

## ⑨ Name Plate Letter(See A-74~A-77 for Details)

Specify your desired letter to be used for Name Plate.

## ⑩ Indicator(See A-78 for Details)

Indicator shall be attached only when Spring Return(45°) is selected as operational method.

\*Indicator cannot be attached to AB-type, YB-type or Acrylic Name Plate.

# Operation Method

## In Case of Rotating Operation Only

Choose the proper code in the list below in case of Rotating the Handle to Left or Right Only.

Code	N	R	RX	
Rotating	Manual Return	Spring Return	Spring Return(Click)	
Operation Pattern	□	← ● →	← ← ● → → →	
Code	R2	R8	NR2	NR8
Rotating	Spring Return to 2.	Spring Return to 8.	Manual return from 8 to 1. Spring Return from 2 to 1.	Spring return from 8 to 1. Manual Return from 2 to 1.
Operation Pattern	← ●	● →	□ ● →	← ● □

## In Case of Rotating and PULL/Push Operations

Switch Unit with Handle for Pull/Push Operation is manufacturable only in case that its operational angle is 45° or 90° . Pull/Push Operation means that an operator should push or pull the handle for rotating it.

Explanation of Pull/Push Operation	Manufacturable Operational Position		
<p>Top View</p>	<p>45° Notch</p>	<p>90° Notch</p>	<p>90° Notch (Separation from the center at 45°)</p>

Code of Pull/Push Operation is composed of [Rotating Operation Code] + [Pull/Push Operation Code] + [Pull/Push Position No.].

Code		Pull/Push Operation	Rotating Operation	
Rotating	Pull/Push		Pushing Position	Pulling Position
N	SF□	Spring Return to Pushing Position	Unrotatable	Rotatable
R	SL□		Rotatable	Unrotatable
	PF□	Manual Return	Unrotatable	Rotatable
	PL□		Rotatable	Unrotatable
	TF□	Spring Return to Pulling Position	Rotatable	Unrotatable
	TL□		Unrotatable	Rotatable

Fill in the □ the proper code of Operational Position for Pull/Push Operation.  
Mark [0] in case that Pull/Push Operation is needed at every Operational Position.  
Contact us for details as for the combinations of manufacturable units.

Example of Commonly Used Pull/Push Operations

Code	NSF0	NSF1	NSF8	NPF0	NPF1	NPF8
Rotating Operation	Manual Return			Manual Return		
Pull/Push Operation	Rotating Operation is Possible at Pulling Position /Spring Return to Pushing Position			Rotating Operation is Possible at Pulling Position /Manual Return to Pushing Position		
Pull/Push Position	Every Position	1	2	Every Position	1	2
Operational Plan						

Code	NPLO	NPL1	NPL8
Rotating Operation	Manual Return		
Pull/Push Operation	Rotating Operation is Possible at Pushing Position /Manual Return to Pulling Position		
Pull/Push Position	Every Position	1	8
Operational Plan			

Code	RSF1	RSL1	RPF1	RPL1	RPL8
Rotating Operation	Spring Return			Spring Return	
Pull/Push Operation	Rotating Operation is Possible at Pulling Position /Spring Return to Pushing Position	Rotating Operation is Possible at Pushing Position /Spring Return to Pushing Position	Rotating Operation is Possible at Pulling Position /Manual Return to Pushing Position	Rotating Operation is Possible at Pushing Position /Manual Return to Pulling Position	
Pull/Push Position	1	1	1	1	8
Operational Plan					

Code	NTF0	NTL0	RTF1	RTL1
Rotating Operation	Manual Return		Spring Return	
Pull/Push Operation	Rotating Operation is Possible at Pushing Position	Rotating Operation is Possible at Pulling Position	Rotating Operation is Possible at Pushing Position	Rotating Operation is Possible at Pulling Position
Pull/Push Position	Spring Return to Pulling Position		Every Position	
Pull/Push Position	Every Position		1	
Operational Plan				



## Key-Handle Operation(Only for Rotating Operation)

This section explains how to select Key-Handle with an original key.(Only 45° and 90° Operation can be manufactured.)

Key-Handle Code is configured with [Rotating Operation Code + Key's Insertion/Pulling position No.]  
Fill the Key's Insertion/Pulling Position No. into □.Fill □ with [0] if you insert/pull the Key at every operational position. Choose the Key No. when you order.



### In Case that Key is Inserted into Only One(1) Place:

Code	Rotating Operation Mark	Operation Angle	Drawing of manufacturable Notch	Key's Insertion/Pulling Position
NK□	Manual Return □	45° 90°		At any 1 place
RK1	Spring Return ↔	45°		At 1.
R2K2	Spring Return to 2. ←	90°		At 2.
R8K8	Spring Return to 8. →			At 8.
NR2K□	□→	45°		At 1. or 8.
NR8K□	←□			At 1. or 2.

### Applicable Key

KEY No.	Key's Shape	Remarks
B9	Convex Shape	Standard Items
B8	Concave Shape	
B3	Convex Shape (Different Pin Position)	Made to Order
B5		
B7		
B1-R	Convex Shape (Only for Clockwise Operation)	
B1-L	Convex Shape (Only for Unclockwise Operation)	
B2	Concave Shape (Different Pin Position)	
B4		
B6		
B10-R	Concave Shape (Only for Clockwise Operation)	
B10-L	Concave Shape (Only for Unclockwise Operation)	

**In Case that Key is Inserted into Two(2) Places:**

Code	Rotating Operation Mark	Operation Angle	Drawing of manufacturable Notch	Key's Insertion /Pulling Position
NK0	Manual Return <input type="checkbox"/>	90°		At Two(2) places (8. & 2.)

**Applicable Key**

KEY No.	Key's Shape	Remarks
B8X	Convex Shape	Made to Order
B9X	Concave Shape	

**In Case that Key is Inserted into More than Three(3) Places:**

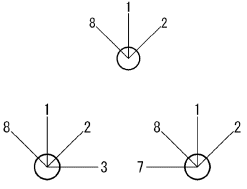
Code	Rotating Operation Mark	Operation Angle	Drawing of manufacturable Notch	Key's Insertion /Pulling Position
NK0	Manual Return <input type="checkbox"/>	45°		At More than Three(3) places

**Applicable Key**

KEY No.	Key's Shape	Remarks
B2X	Convex Shape	Made to Order
B3X	Concave Shape	

**Reference**

<Key Diagram for Reference>

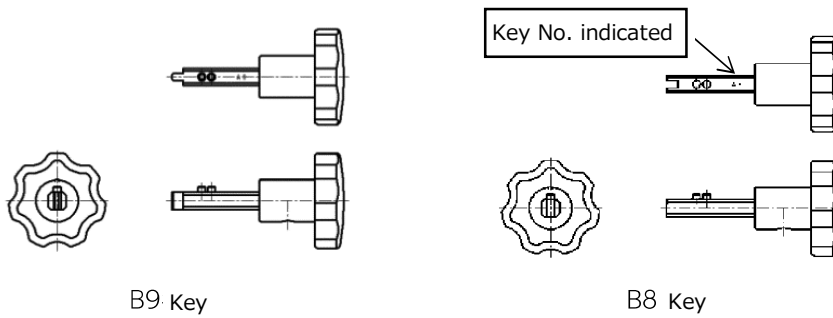

# Contact Type

Be sure to specify a proper Integration Unit by referring to the table below, if you choose Silver Twin Contact or Gold Twin Contact.

Code	Contact Type	Designation Example of Integration Units of Silver Twin/Gold Twin Contact	
Nothing Marked	Silver Contact (Standard)	-	Silver Contact is applied to all the contacts.(Standard)
V	0	V0	Silver Twin Contact is integrated into all the units.
	□	V5	Silver Twin Contact is integrated into the 5th unit.
	□~□	V1~3	Silver Twin Contact is integrated into the 1st~3rd units.
	□·□	V1·10	Silver Twin Contact is integrated into the 1st and 10th units.
G	0	G0	Gold Twin Contact is integrated into all the units.
	□	G5	Gold Twin Contact is integrated into the 5th unit.
	□~□	G1~3	Gold Twin Contact is integrated into the 1st~3rd units.
	□·□	G1·10	Gold Twin Contact is integrated into the 1st and 10th units.

## Reference

### ❖ Differences between Single contact and Twin Contact

Structure of Contact Unit of B Type Cam Switch

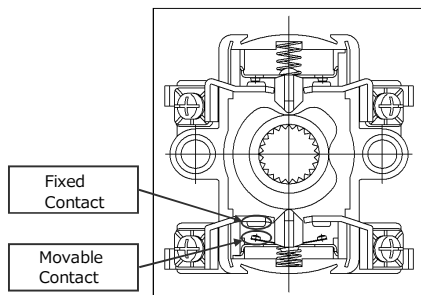

Silver Single Contact (Standard)

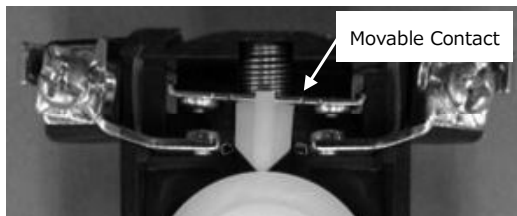

Silver Twin/Gold Twin Contact

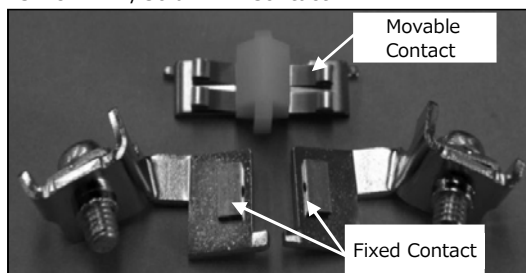

Wipe Structure of Contact

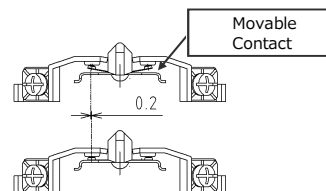

As illustrated in above, the movable contact slides by about 0.2mm from the start of contacting to the end of the contacting. The material used in the movable contact in Twin Contact is phosphorous bronz. Therefore, the contact has a wiping function to wipe off any oxide-coating or sulfide-coating which happens on the contact surface.

←With the convex-shape of the movable contact, stable contact resistance was realized.

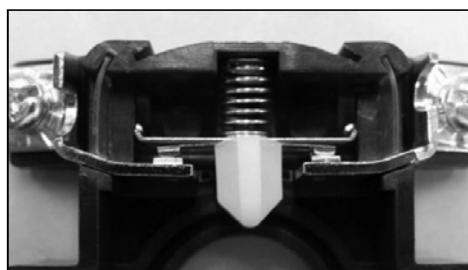

#### • Higher Contact Reliability (Silver Twin Contact)

We adopted cross bar contact(Bonded contact),not plated contact in order to make its contact reliability higher.This type of contact has been used in railway trains thanks to such heigher reliability.

#### • Minute Voltage/Current Usage (Gold Twin Contact)

In the field of minute current, coating or sulfide caoting on the contact surface cannot be removed even by use of arc,which may lead to a rise in contact resistance and cause a contacting failure. However, Gold Contact(Cross bar contact is used for its movable contact) is able to control any rise in contact resistance thanks to its materials' property.Unlike plated contact,no pinholes happen. Therefore,very high level of reliability is secured in case of Gold Contact.

Gold Twin Contact has been used in chemical plants,especially in the environment where any coating tends to happen on contacts and in the field of minute current used for sequencer control and so on.

## Terminal Cover

Side Terminal Cover is for protecting the terminal unit from workers' fingers and hands.  
 Upper Terminal Cover is for protecting the terminal unit from falling parts.  
 The combined use of Side Cover and Upper Cover is impossible.

Specification	No Terminal Cover	Side Cover(1~6 Units)*	Upper Cover(1~12 Units)
Code	No Code	C	LC
Appearance			

\* Side Cover covers from the side of End-Plate to 6th units in case of 7 or more units.

## Handle Types

### No Handle

Code	NN

### Handle (Standard Size)

Handle Shape		Chrysanthemum	Pistol	Oval	Stick
Code	Black	RK	PK	VK	SK
	Red	RR	PR	VR	SR
	Green	RM	PM	VM	SM
Appearance					

Handle Shape		Arrow	Boat
Code	Black	YK	FK
	Red		FR
	Green		FM
Appearance			

## Handle (Large Size)

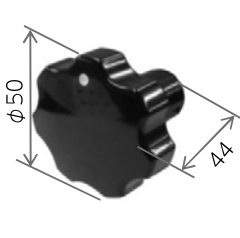
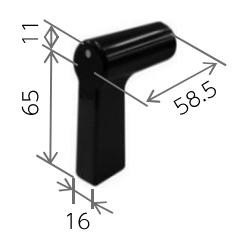
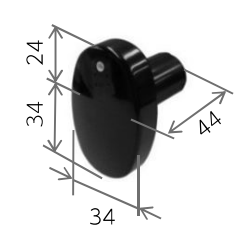
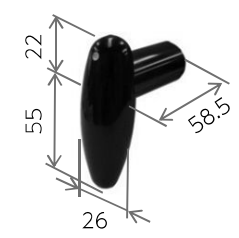
Handle Shape		Large Chrysanthemum	Large Pistol	Large Oval	Large Stick
Code	Black	ARK	APK	AVK	ASK
	Red	ARR	APR	AVR	ASR
	Green	ARM	APM	AVM	ASM
Appearance					

## Special Handle

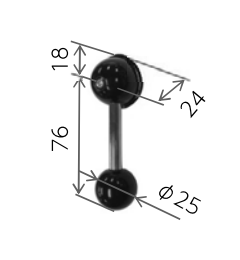
Handle Shape		Ball
Code	Black	GK
	Red	
	Green	
Appearance		

Color	Specification
Black	Color close to N1.5
Red	Color close to 7.5R4.5/14
Green	Color close to 7.5BG3/3.5

## Name Plate Stand (Escutcheon)

B-Type,AB-Type,YB-Type

Code	Specifications
N	No Name Plate Stand
K	Black(Color Close to N1.5)
A	Gray Blue(Color Close to 7.5BG4/1.5)※

JB-Type

Code	Specifications
K	Black(Color Close to N1.5)
K(S10)	Black (for1.0mm Acrylic Name Plate)

※Gray Blue Color is not available in case that Basic Type is JB or YB-Type.

## Name Plate Type

Code	Specifications / Descriptions	Thickness (mm)
N	Standard Aluminium NP(Screen Printing+Baking Clear Coating)	0.5
S	Stainless Name Plate(Delustering Polish)	0.5
A	Acrylic Name Plate(Backside's Inscription Letter Color:Black) ※	1.0

※Acrylic Name Plate is not available in case that Basic Type is YB-Type.

## Name Plate Letters

Code	Specifications	Remarks
Nothing Filled	No Name Plate	No Name Plate in case of No Mark.
0	Blank	
X	Inscriptions of Customized Letters	See pages A-75~A-76 for the inscription position before specifying the position and letters of inscription.
□□□	Letter-Printed NP	See pages A-77 to check the list of Printed Name Plates and choose your desired Name Plate Code.(1~3 digits)

### Reference

#### ❖ Inscription Letters(Characters) Specification

Specifications		
Language	Full-size Japanese(Kanji,Hiragana,Katakana) and Half-size English Letters & Figures	
Font	Roundish Gothic Type	
Letter Width	Depends on the number of Inscribed Letters	
No. of Letters Inscribable (per line)	N・S	Up to 10 Full-Size Letters/20 Half-Size Letters of Standard letter Height.
	P・Each Operation Position	Up to 4 Full-Size Letters / 8 Half-Size Letters of Standard letter Height.

#### ❖ Details of Inscribed Letters

Letter Position	Name Plate Spec				
	B	AB	JB	YB	
N	1 line	4	4.5	4	4
	2 line	2.8	3.2	/	2.8
S	1 line	3.4	3.5	4	3.4
	2 line	2.8	3.2	3.2	2.8
P	2.7	3	4	2.7	
K (Key No.)	2	2	/	/	

Standard Letter Height

Full-Size 10 Letters	操作開閉器彫刻位置図	4
Half-Size 20 Letters	0123456789ABCDEFGHIJK	4
Full-size & Half-Size Mixed Letters	操作開閉器ABCDEFGHIJK	4
37		

(Sample1)  
Max No. of letters Inscribed for N section, B-Type

Full-Size 10 Letters	操作開閉器彫刻位置図	3.4
Half-Size 20 Letters	0123456789ABCDEFGHIJK	3.4
Full-size & Half-Size Mixed Letters	操作開閉器ABCDEFGHIJK	3.4
35		

(Sample2)  
Max No. of letters Inscribed for S section, B-Type

Full-Size 10 Letters	彫刻位置	3.4
Half-Size 20 Letters	01234567	3.4
Full-size & Half-Size Mixed Letters	彫刻4567	3.4
12		

(Sample3)  
Max No. of letters Inscribed for Each Operation Position, B-Type

### ❖ Inscribing Position

When the 1st line inscription and the 2nd line inscription coexist, the 1st line inscription should be done on the 1st line, and the 2nd line inscription on the second line.

In case of Key Handle, the shaft hole diameter in the center of the name plate shall be  $\phi 15$ .

※  shows the hole for an indicator.

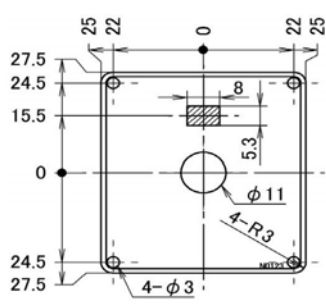
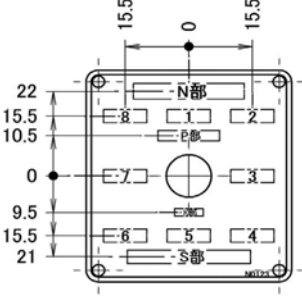
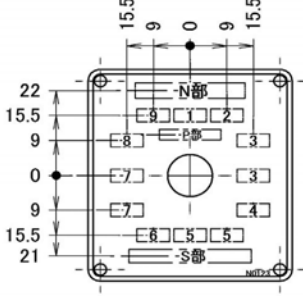
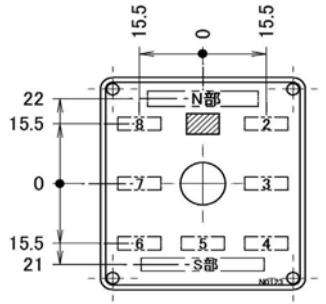
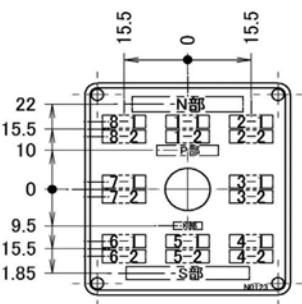
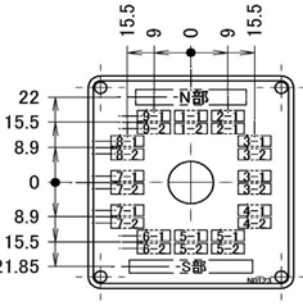
NP Type	Name Plate Dimensions	45° Operation NP letters' Position	30° Operation NP letters' Position
B Type (Screwing)			
	 <p>※ Need to consult with us if you need inscription for "1" on the name plate with an indicator.</p>		

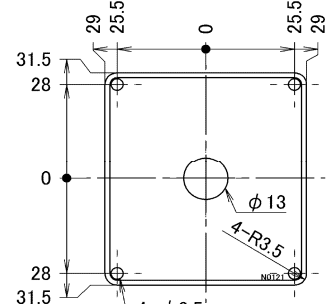
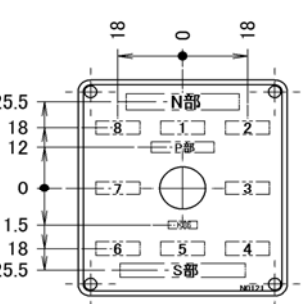
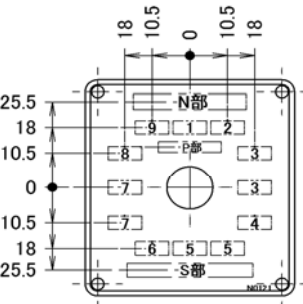
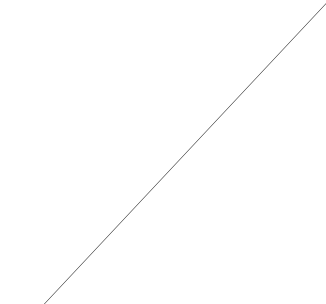
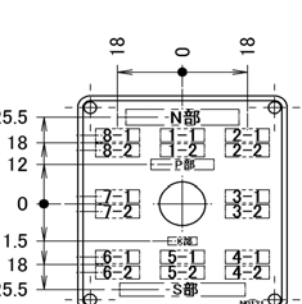
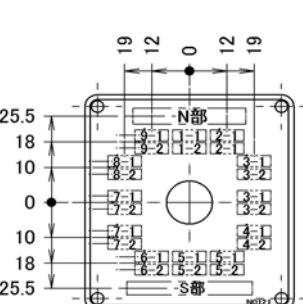
NP Type	Name Plate Dimensions	45° Operation NP letters' Position	30° Operation NP letters' Position
AB Type (Screwing)			
			

Parts code may be printed in the right lower section of the aluminium name plate.

NP Type	Name Plate Dimensions	45° Operation NP letters' Position	30° Operation NP letters' Position
JB Type (One-Touch)			
	<p>※ Need to consult with us if you need inscription for "1" on the name plate with an indicator.</p>		

NP Type	Name Plate Dimensions	45° Operation NP letters' Position	30° Operation NP letters' Position
JB Type (One-Touch)			

Parts code may be printed in the right lower section of the aluminium name plate.



## Printed Name Plate

Letters Pre-printed Name Plate is available only when Basic Model is A-Type, AB-Type or JB-Type.  
(Except for Key-Handle type.)

[Remarks] ○ : Printed NP is available    × : Printed NP is Not available [Choose N-X(to be inscribed)]

Code	N	6	7	8	1	2	3	4	5	S	B-Type	AB-Type	JB-Type	Code
1	交流電流計		切	1	2	3	切				○	○	○	1
2	交流電流計		切	R	S	T	切				○	○	○	2
4	交流電流計		切	R	S	T	N				○	×	○	4
7	交流電圧計		切	1-2	2-3	3-1	切				○	○	○	7
8	交流電圧計		切	R-S	S-T	T-R	切				○	○	○	8
14	交流しゃ断器			切		入					○	○	○	14
16	電磁接触器			切		入					○	○	○	16
19				手動		自動					○	○	○	19
21				NO.1		NO.2					○	×	○	21
22				切		入					○	○	○	22
31	交流電流計		切	R	N	T	切				○	○	○	31
32	交流電圧計		切	R-N	N-T	T-R	切				○	○	○	32
37				手動	切	自動					○	×	○	37
43				停止		運転					○	×	○	43
50				停止		起動					○	×	○	50
86				現場		中央					○	×	○	86
93				OFF		ON					○	×	○	93
107				閉		開					○	×	○	107
108				単独		連動					○	×	○	108
128				手動	断	自動					○	×	○	128
152	VOLTMETER		0	R-S	S-T	T-R	0				○	×	○	152
154	AMMETER		T		0		R		S		○	×	○	154
155	AMMETER		0	R	S	T	N				○	×	○	155
156	VOLTMETER	T-R	S-T	R-S	0	R-N	S-N	T-N			○	×	○	156
158	AMMETER		0	R	S	T	0				○	×	○	158
160	交流電流計		切	R	S	T	切				○	×	○	160
162				旧盤		新盤				切替開閉器	×	○	×	162
163	遮断器			切		入				引いて操作	○	×	○	163
164	開閉器			切		入				引いて操作	○	×	○	164
165				旧盤		新盤				操作開閉器	○	×	○	165
200	断路器			切		入					×	×	○	200
201	交流遮断器			切		入					×	×	○	201
202	操作場所切換器			直接		遠方					×	×	○	202
203	操作場所切換器			現場		中央					×	×	○	203
204	受電回線選択			1号線		2号線					×	×	○	204
205	受電回線選択			2号線		1号線					×	×	○	205
206	ループ切換			除外		使用					×	×	○	206
207	タップ切換器			手動		自動					×	×	○	207
208	LRTタップ			降圧		昇圧					×	×	○	208
209	電圧計切替器			210V		105V					×	×	○	209
210	交流電圧計		切	1-N	N-2	2-1	切				×	×	○	210
211	交流電流計		切	1	N	2	切				×	×	○	211

Printed Name Plate with Indicator hole.

Code	N	6	7	8	1	2	3	4	5	S	B-Type	AB-Type	JB-Type	Code
14	交流しゃ断器			切		入					○	×	×	14
16	電磁接触器			切		入					○	×	×	16
22				切		入					○	×	×	22
93				OFF		ON					○	×	×	93

# Indicator

---

Indicator can be additionally mounted only when Operation Method is Spring-Return-Type (Operation Angle 45°). Indicator cannot be mounted in case that the basic type is AB-Type and YB-Type, and in case that Acrylic Name Plate is used.

※Special name plate designed for indicator is used in case that an indicator is additionally mounted.

Code	Indicator
Nothing Filled	W/O Indicator
(W)	W/ Indicator

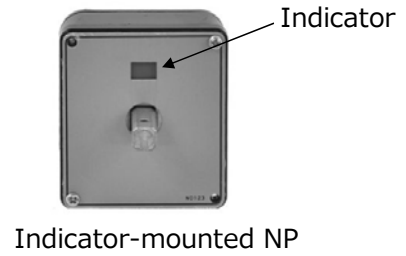
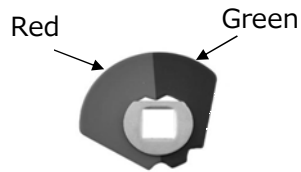

# List of Major Contact Diagrams

Applicable Types : B-Type, WB-Type, WBO-Type, TB1S-Type (TB1-Type), EB-Type, LB-Type, and MSB-Type.

See and carefully check the following table for choosing a proper Contact Diagram.

The number of the units, which can be manufactured, depends on the type and operational specifications you need.

## Maximum Number of the Unit you can Choose per Type.

Type	Operational Specification						
	Rotating	Manual Operation	Spring Return	Manual Operation	Spring Return	Manual Operation	Spring Return
	Pull/Push	Manual Operation			Spring Return		
B		10	6	10	6	10	6
WB		10	6				
WBO		3	3				
TB1S(TB1)		6	5				
EB w/Signal Light		2	2				2
EB w/o Signal Light		3	3				3
LB w/Signal Light		2	2	2	2	2	2
LB w/o Signal Light		3	3	3	3	3	3
MSB w/Signal Light		5	5	5	5	5	5
MSB w/o Signal Light		5	5	5	5	5	5

## Remarks

### ❖ Contact's Operation Types and How to Indicate them

Operation is indicated from the handle of Operation Switch.

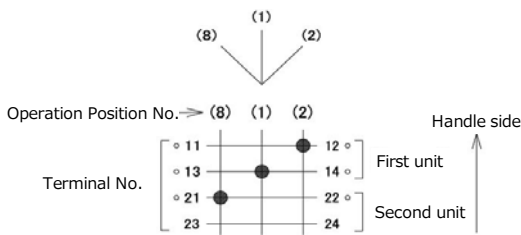

※Standard Terminal Numbers go like this : 11-12, 13-14, 21-22, 23-24...

Contact's OperationType	How to Indicate	Details on Operation
Single Contact		The contact between the terminals turn ON at the designated positions(●).
Continuous Contact		Contacts on the thick horizontal line turn ON continuously.
Lap Contact (For 45°/90° Operations only)		Two or more contacts. One of the contacts turns OFF at the halfway of a notch while other(s) turns ON. Lapping points are connected with a dotted line.
Residual Contact (For Spring-Return System·For 45° Operation only)		Contact turns ON at a ○-marked position. Even when an operator returns the handle to the original position, contact stays ON. Then, when the operator moves the handle in an opposite direction, contact turns OFF and returns to the original status.
Pull/Push Contact		Contact turns ON or OFF by pulling or pushing. Contact doesn't ON or OFF by rotating. ○ means contact turns OFF at pushing position, and turns ON at pulling position. ● means POC turns ON at pushing position, and turns OFF at pulling position.

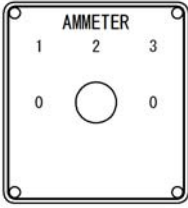
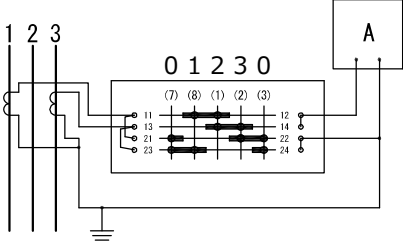
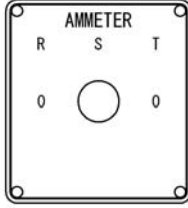
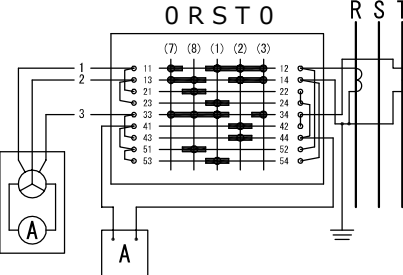
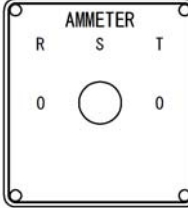
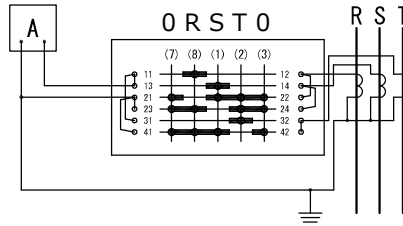
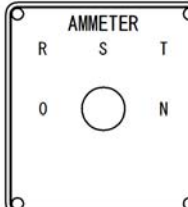
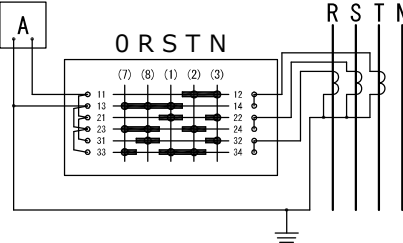
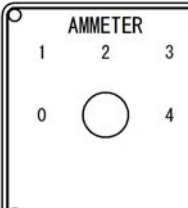
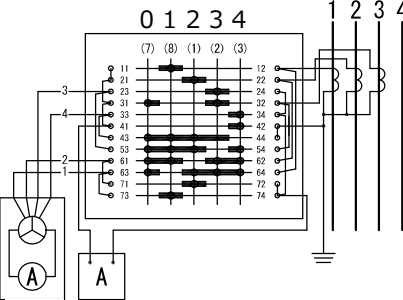
Usage	B-Type NP Indication Example.	Contact Diagram Codes and Contact Diagram Chart
	N-X	2AB
<p>AC Ammeter</p> <p>3-Wire System C.T. 2 points V-Connection Meter Off-Circuit Disconnecting System</p>		
<p>AC Ammeter</p> <p>For Measuring at two (2) or more points. Meter Off-Circuit Disconnecting System</p>	<p>N-158</p> 	<p>5AB</p> <p>0 R S T 0</p> 
<p>AC Ammeter</p> <p>3-Phase 3-Wire system C.T. points Switchover Meter Off-Circuit Disconnecting System</p>	<p>N-158</p> 	<p>4A</p> <p>0 R S T 0</p> 
<p>AC Ammeter</p> <p>3-Phase 4-Wire system C.T. 3points Y-Connection Meter Off-Circuit Disconnecting System</p>	<p>N-155</p> 	<p>3AN</p> <p>0 R S T N</p> 
<p>AC Ammeter</p> <p>3-Phase 4-Wire system For Measuring 2 or morepoints. Meter Off-Circuit Disconnecting System</p>	<p>N-X</p> 	<p>7AB</p> <p>0 1 2 3 4</p> 

Usage	B-Type NP Indication Example.	Contact Diagram Codes and Contact Diagram Chart
	N-155	5AD
AC Ammeter  C.T. 4-points Switchover		
AC Ammeter  3-Phase 4-wire System C.T. 3-points Switchover In case of using Differential Relay.		
AC Ammeter  C.T. 7-points Switchover		
AC Ammeter  3-Phase 3-Wire System 2-Lines		
AC Ammeter  C.T. 1-points Switchover		

Usage	B-Type NP Indication Example.		Contact Diagram Codes and Contact Diagram Chart	
	N-152		2V	
AC Voltmeter  3-Wire System C.T. 2-points V-Connection				
AC Voltmeter  3-Phase 3-Wire System 1-Line  Single Phase 1-Line				
AC Voltmeter  3-Phase 4-Wire System P.T. 3-Points Y-Connection Between Phase Lines				
AC Voltmeter  3-Phase 3-Wire System 2-Lines				
AC Voltmeter  3-Phase 4-Wire System Between Phases and Between Phase Lines				
AC Voltmeter  3-Wire System P.T. 2-Points V-Connection				

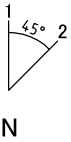

**1 Unit**

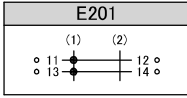
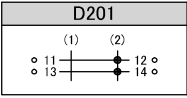

**2 Units**

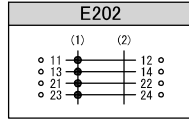
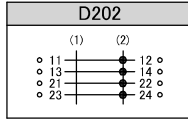

**3 Units**

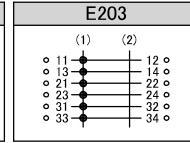
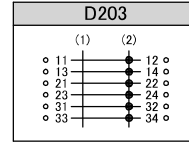

**4 Units**

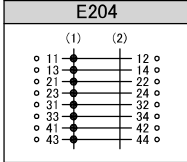
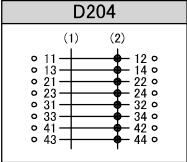

**5 Units**

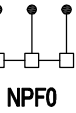
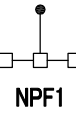
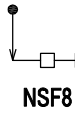
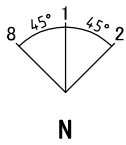
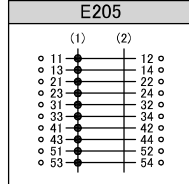
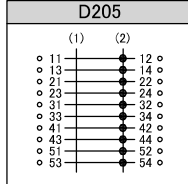

**1 Unit**

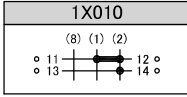
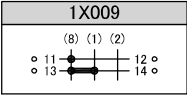
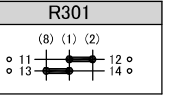
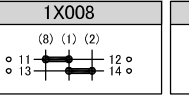
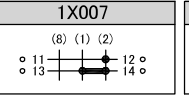
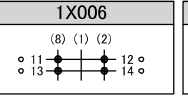
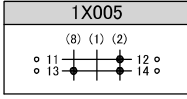
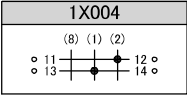
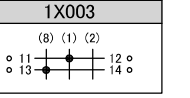
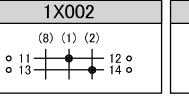
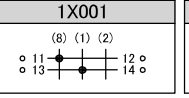
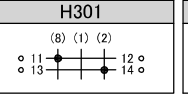
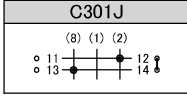
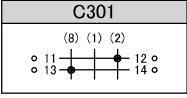

**2 Units**

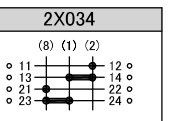
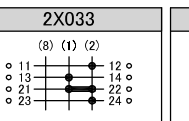
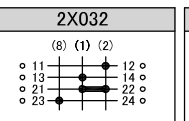
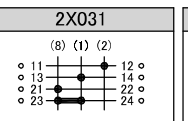
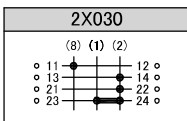
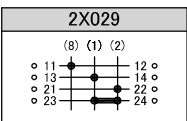
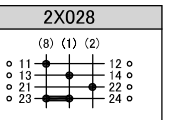
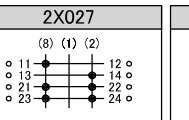
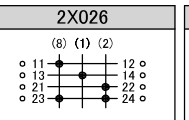
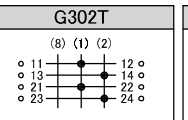
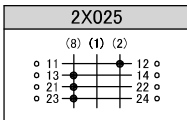
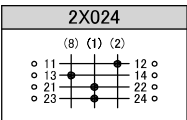
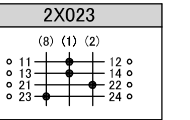
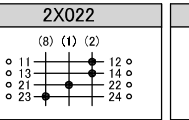
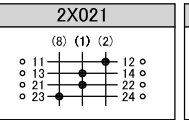
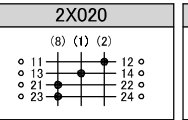
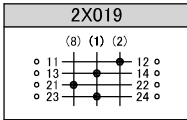
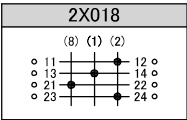
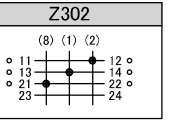
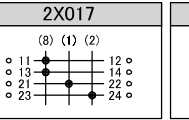
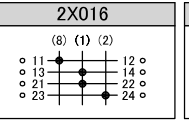
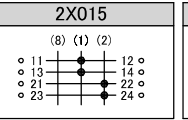
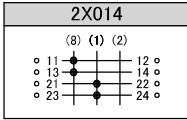
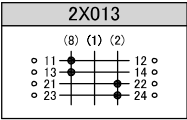
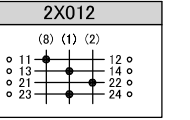
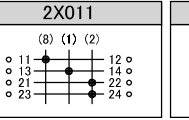
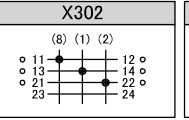
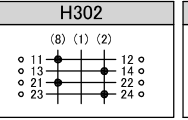
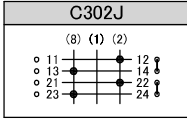
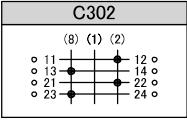





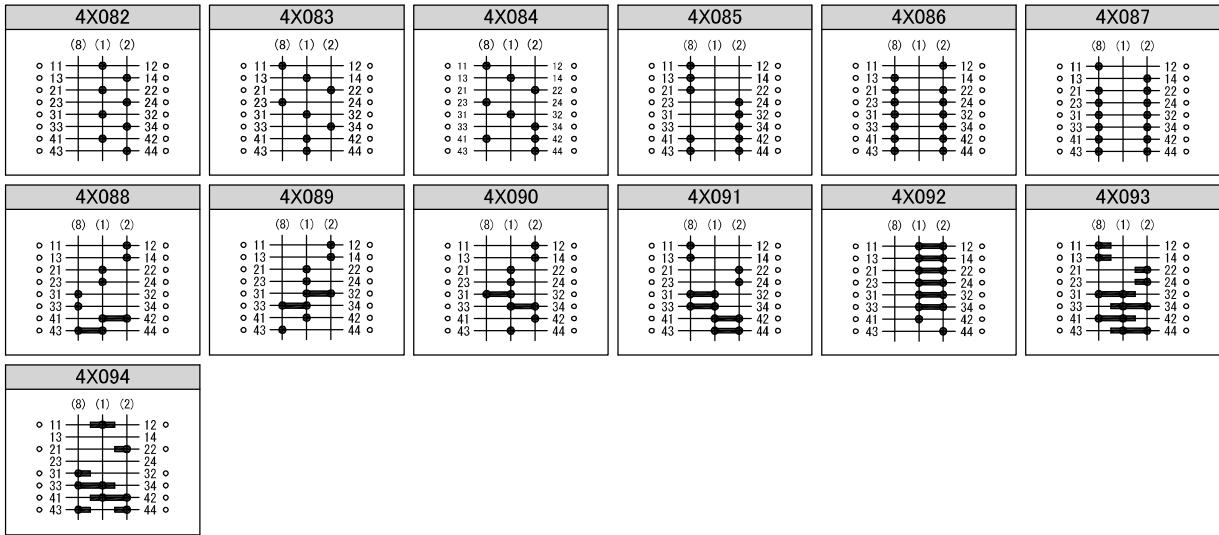

**5 Units**

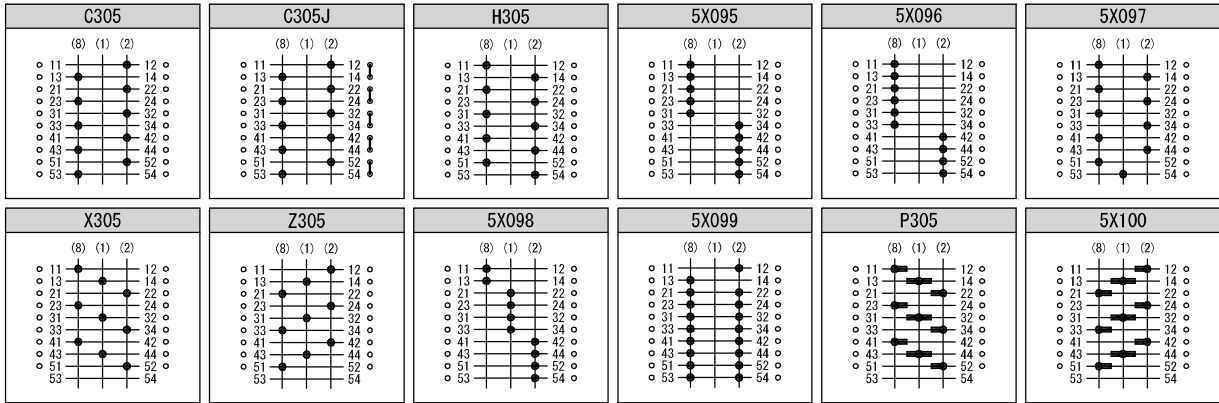

**6 Units**

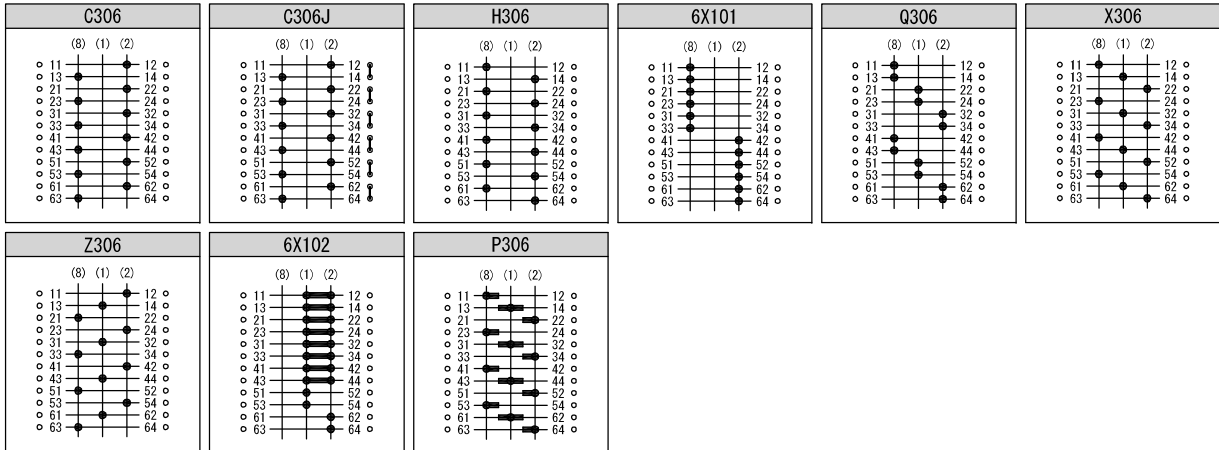

**7 Units**

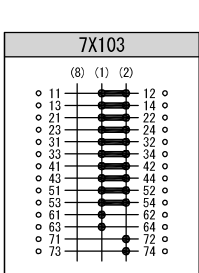
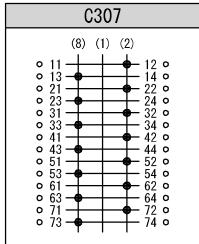

**8 Units**

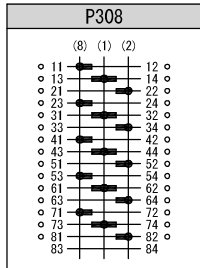
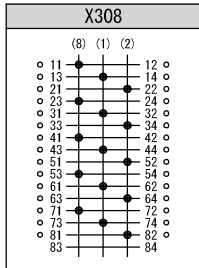
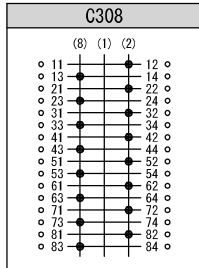

**9 Units**

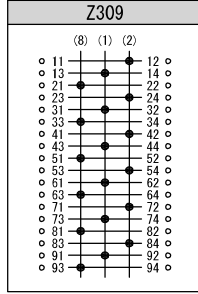
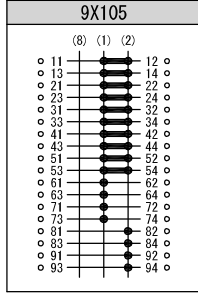
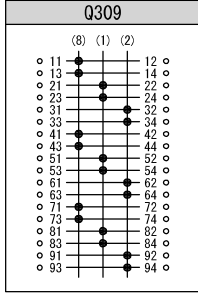
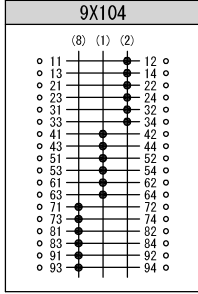
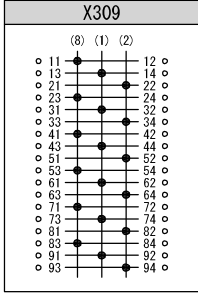

**10 Units**

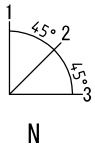
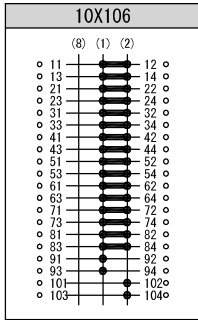
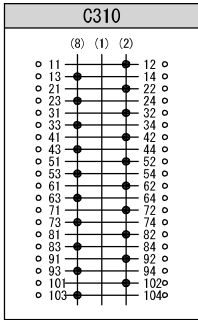

**1 Units**

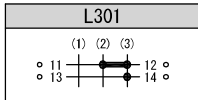
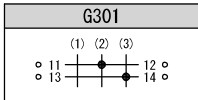

**2 Units**

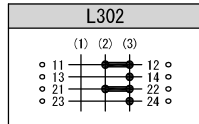
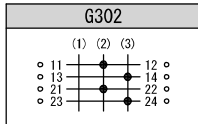

**3 Units**

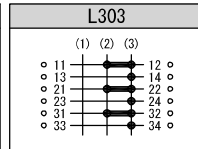
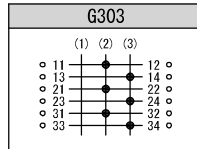

**4 Units**

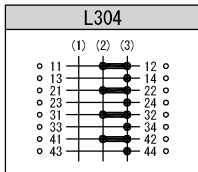
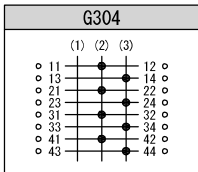

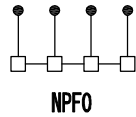
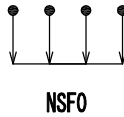
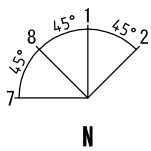

**2 Units**

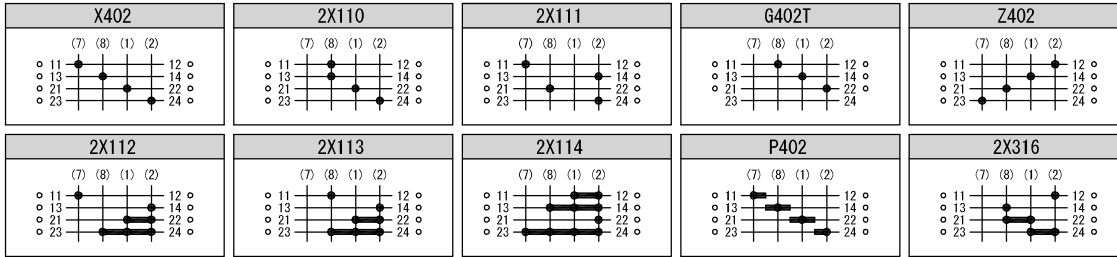

**3 Units**

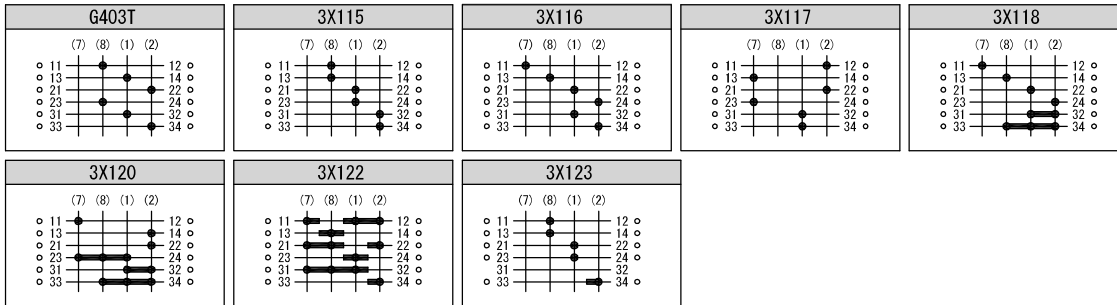

**4 Units**

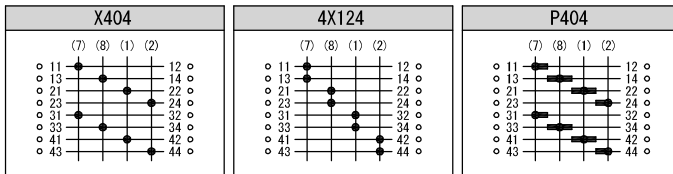

**5 Units**

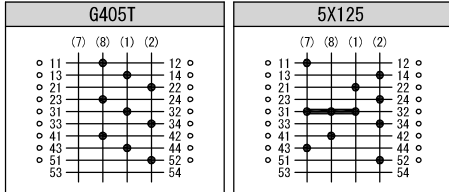

**6 Units**

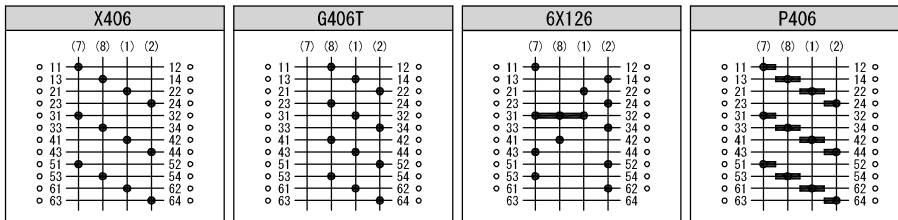

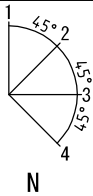

N

**2 Units**

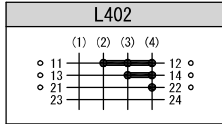
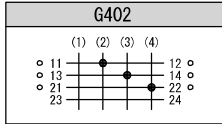

**3 Units**

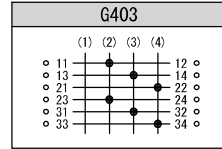

**4 Units**

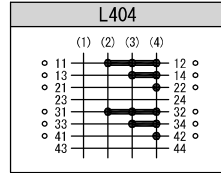

**5 Units**

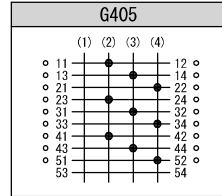

**6 Units**

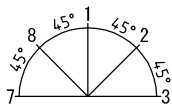
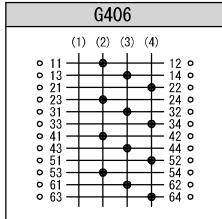

N

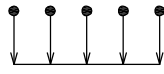

NSFO

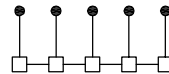

NPFO

**2 Units**

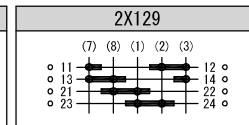
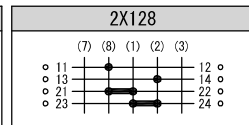
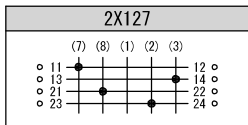

**3 Units**

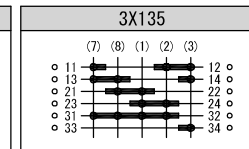
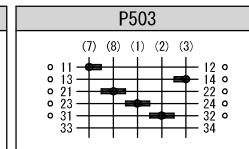
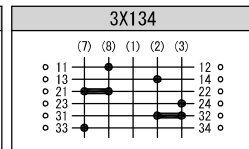
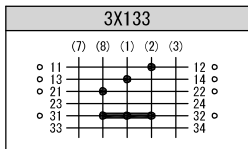
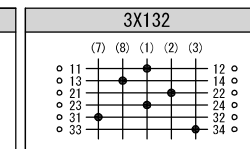
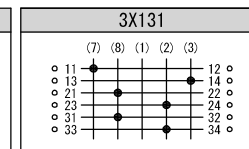
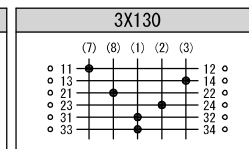
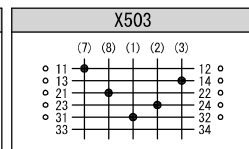
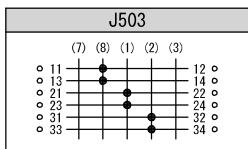

**4 Units**

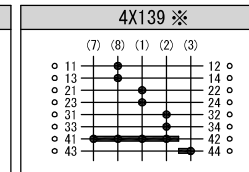
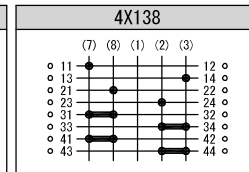
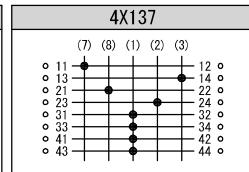
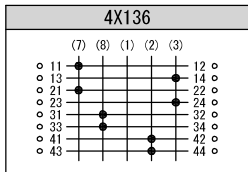

**5 Units**

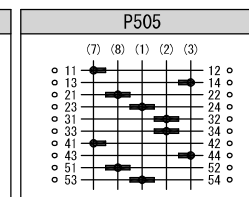
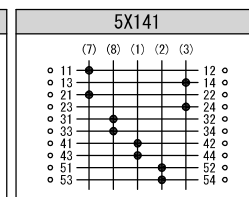
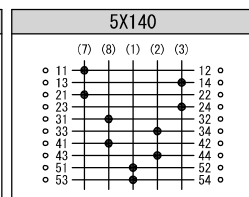
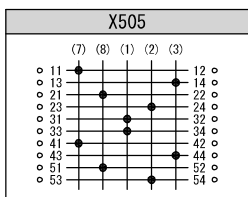

※ Single contact and Lap contact of "4X139" may cause a lapping momentarily. See Page A-100 for more information about Momentary Lap.

**6 Units**

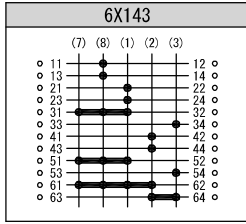
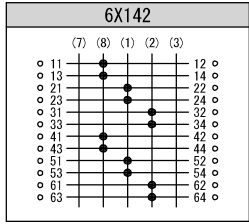

**7 Units**

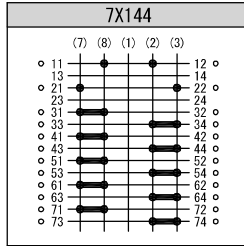

**8 Units**

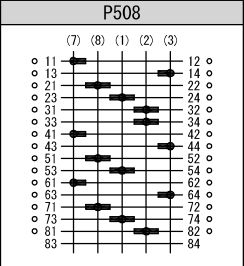
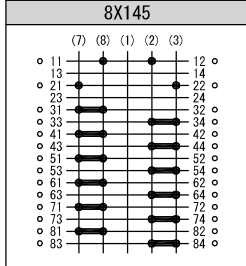
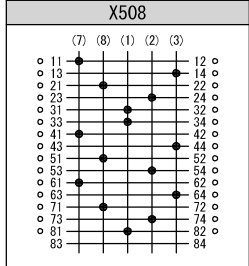

**10 Units**

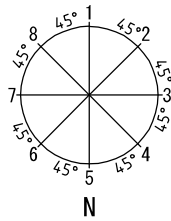
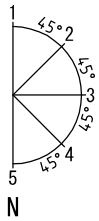
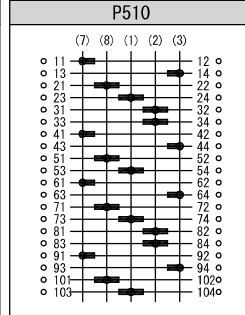
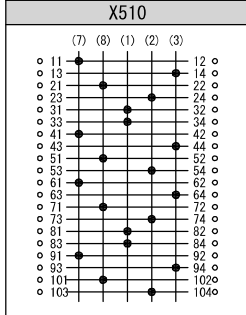

**4 Units**

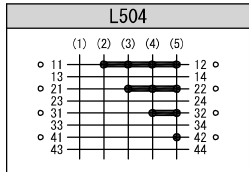

**8 Units**

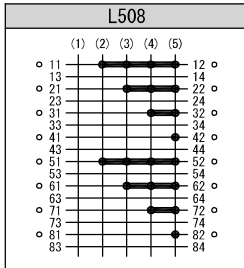

**4 Units**

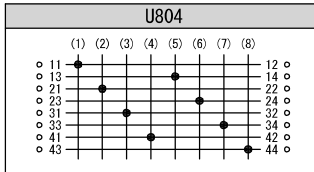

**7 Units**

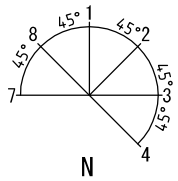
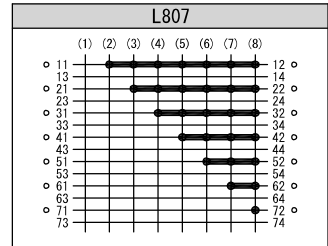

**3 Units**

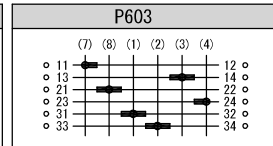
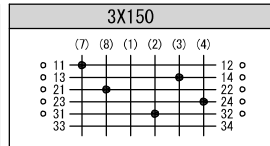
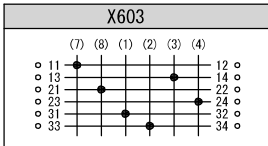

**6 Units**

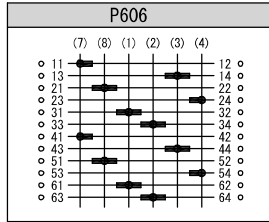
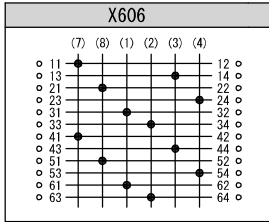

**9 Units**

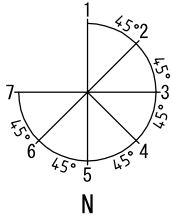
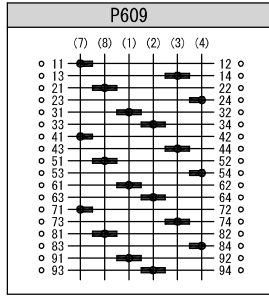
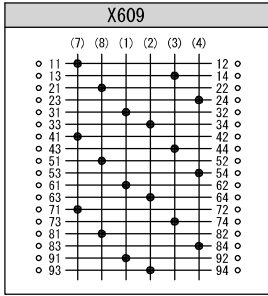

**6 Units**

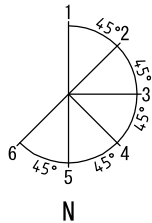
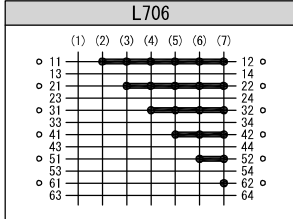

**3 Units**

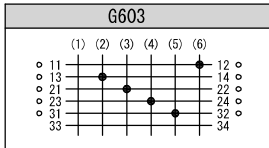

**5 Units**

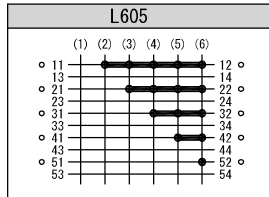

**6 Units**

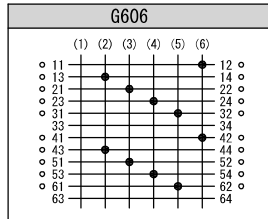

**10 Units**

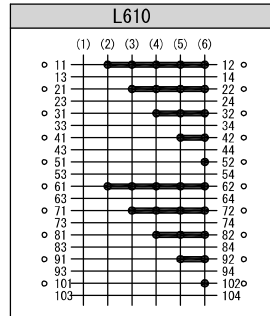

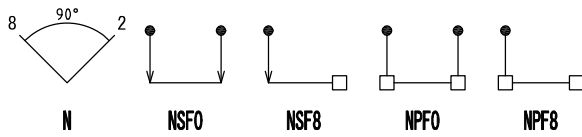

### 1 Unit

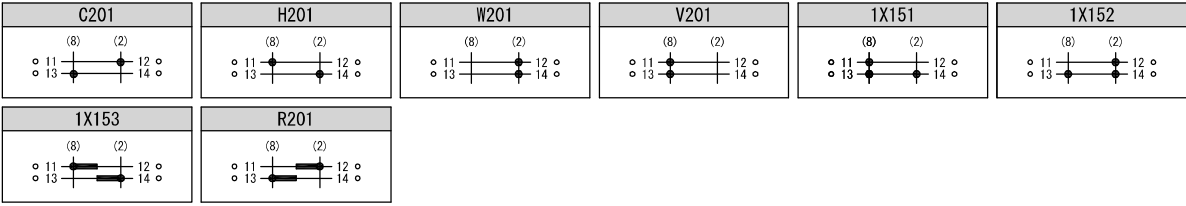

### 2 Units

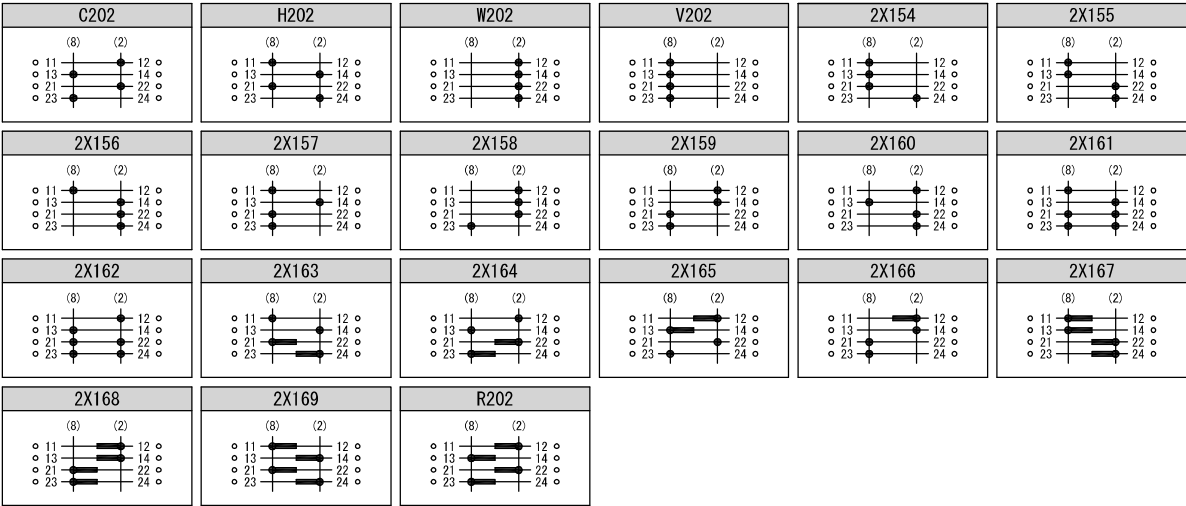

### 3 Units

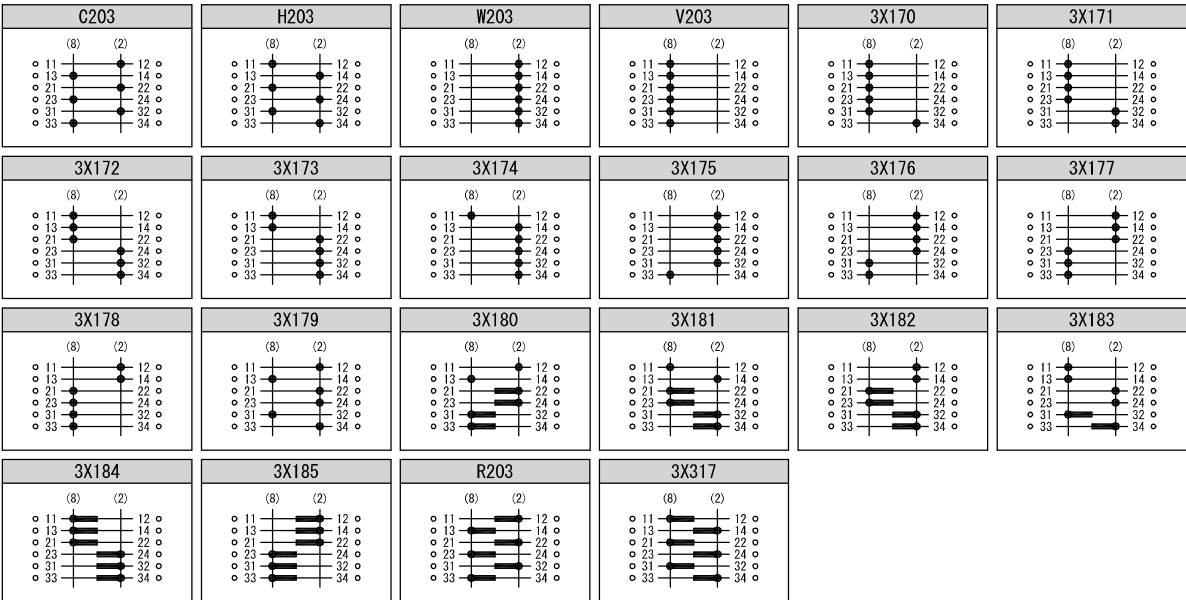

### 4 Units

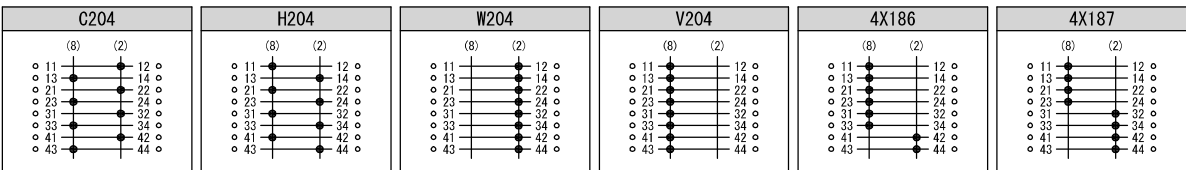

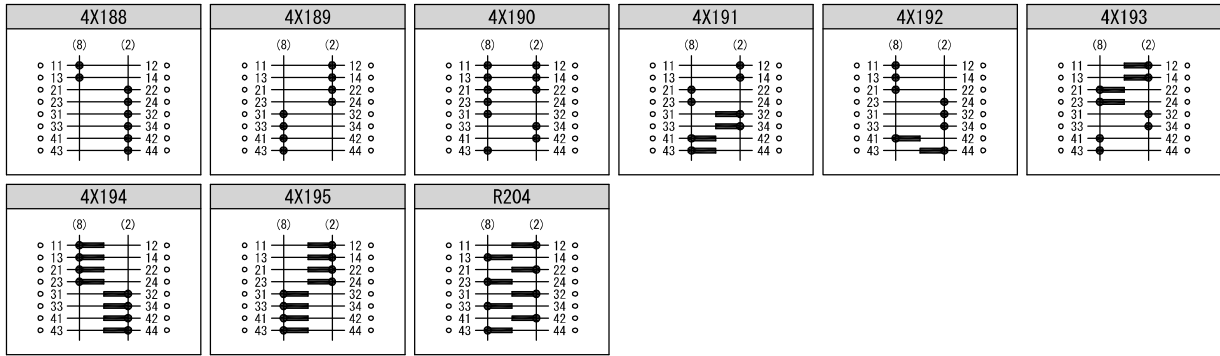

### 5 Units

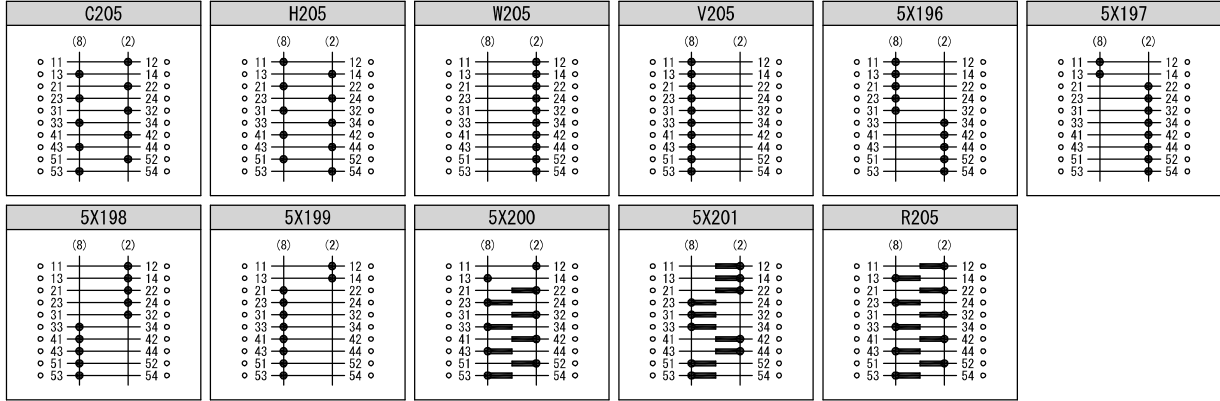

### 6 Units

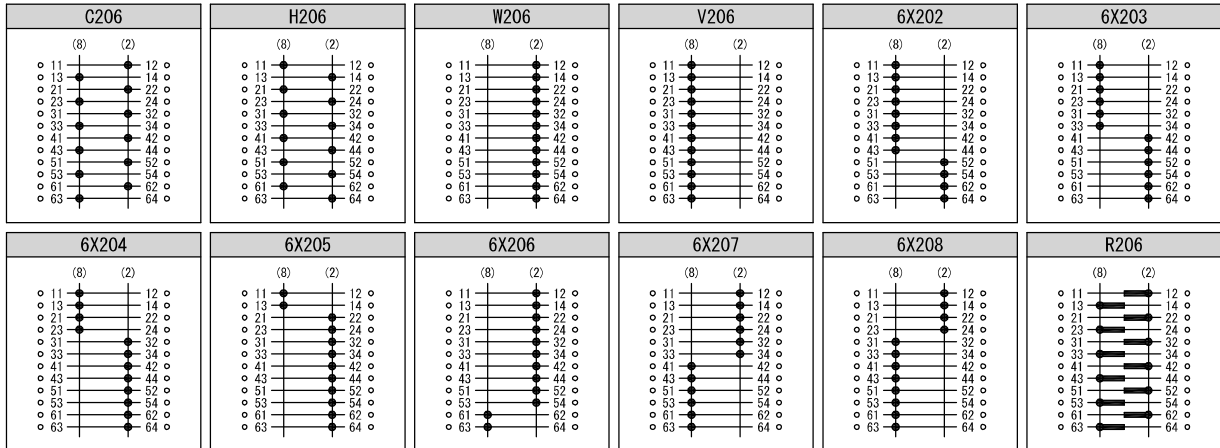

### 7 Units

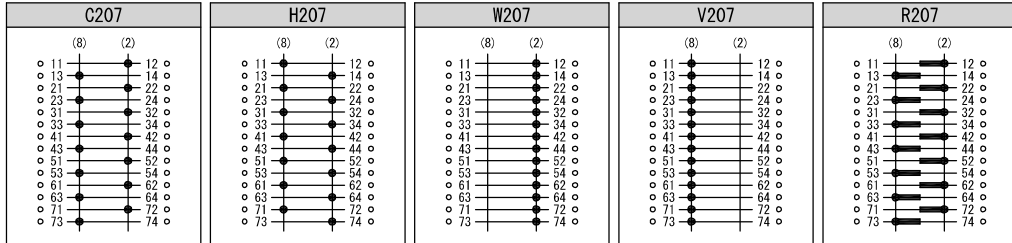



**8 Units**

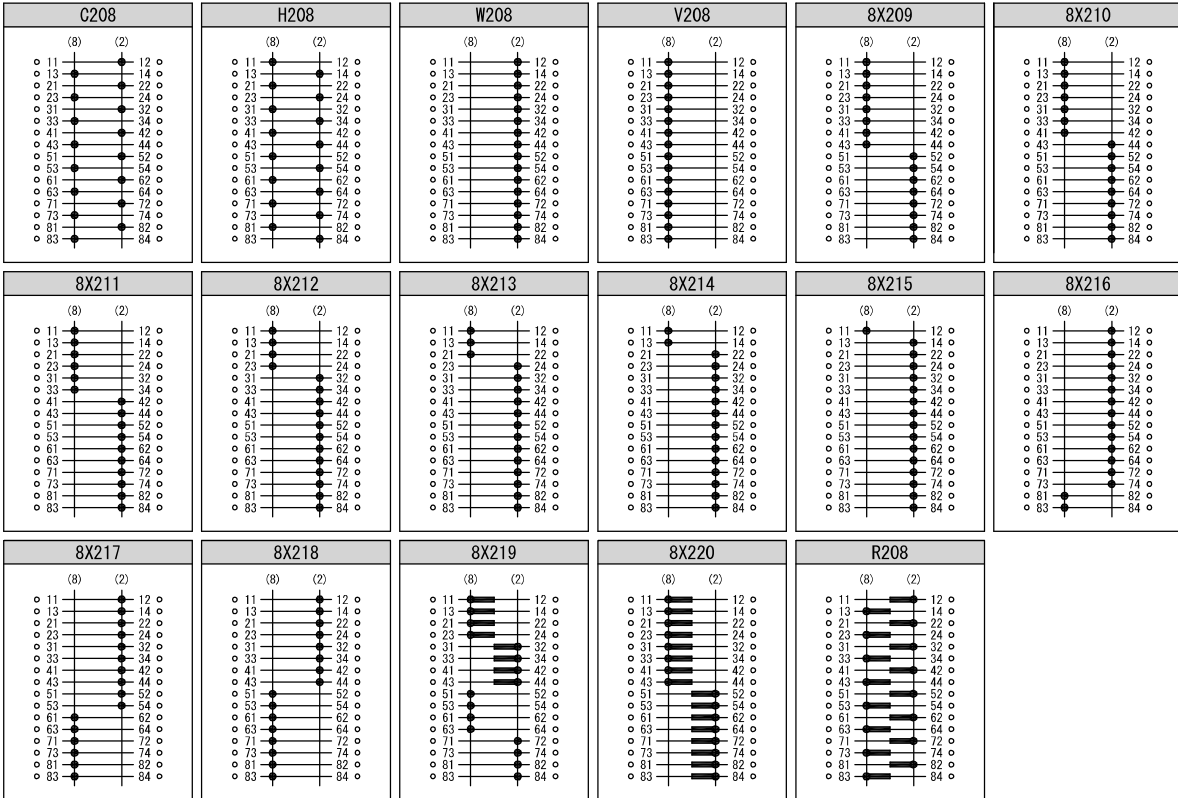

**9 Units**

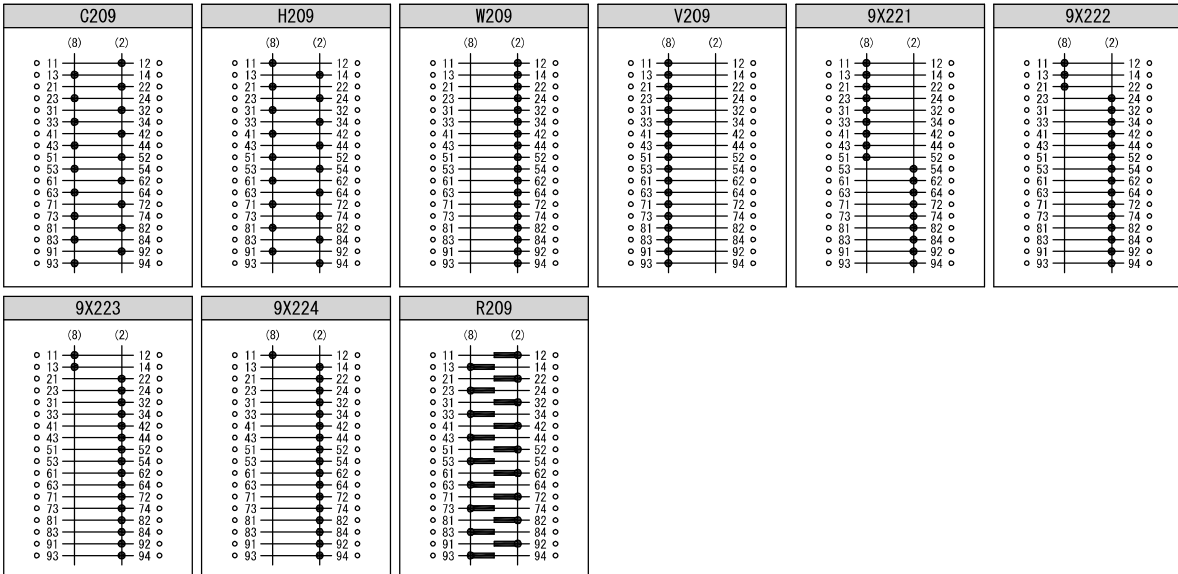

**1 0 Units**

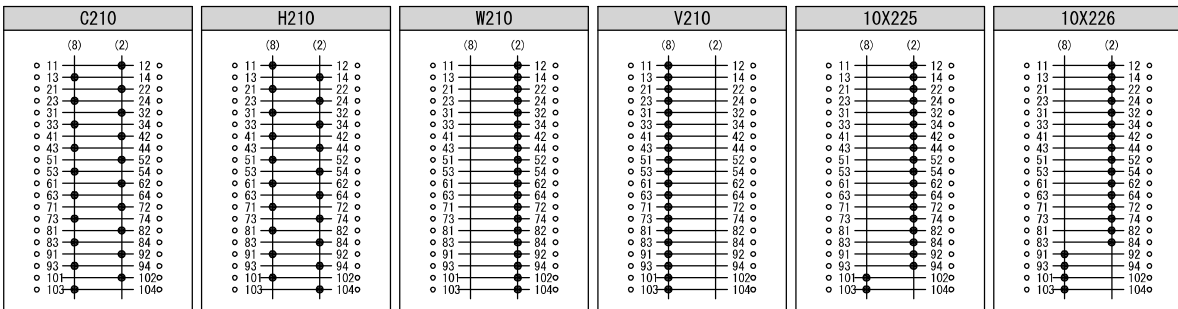

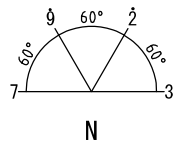
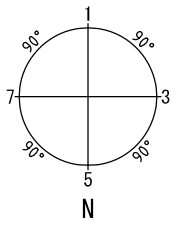
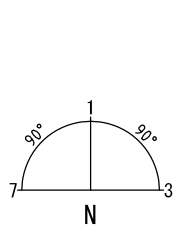
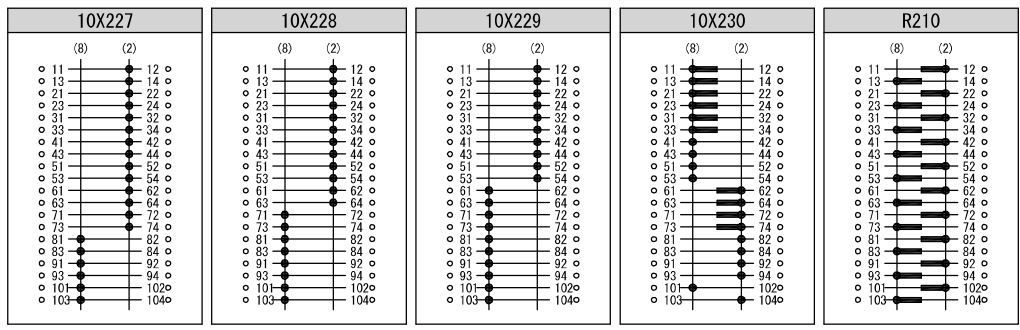

**5 Units**

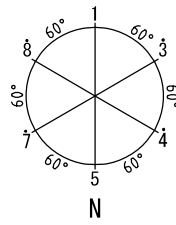
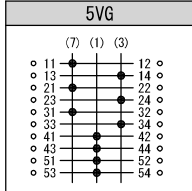

**2 Units**

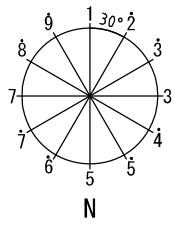
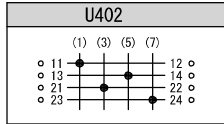

**4 Units**

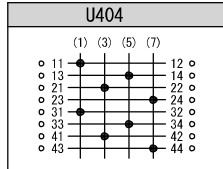

**3 Units**

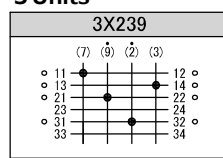

**3 Units**

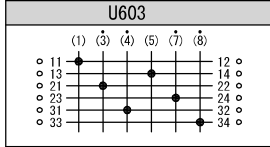

**6 Units**

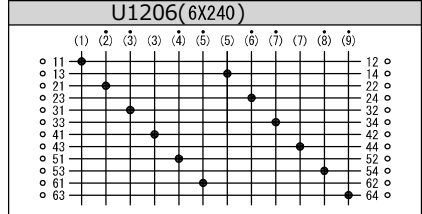

**6 Units**

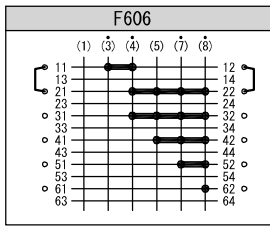

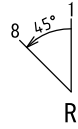

**1 Unit**

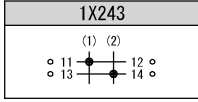
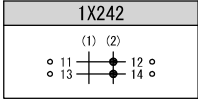

**2 Units**

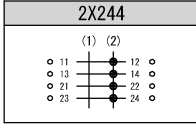

**1 Unit**

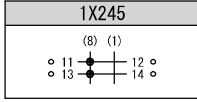

**2 Units**

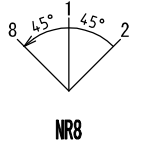
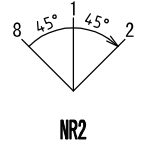
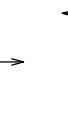
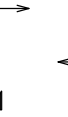
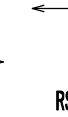
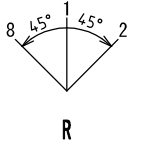
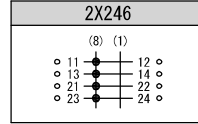

**1 Unit**

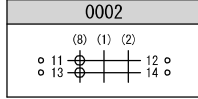
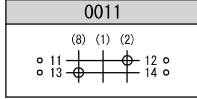
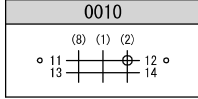
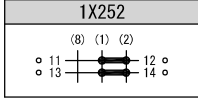
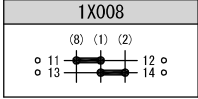
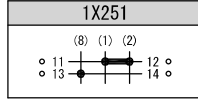
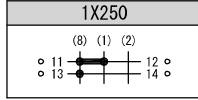
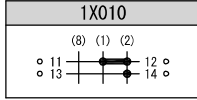
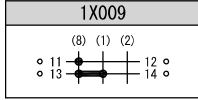
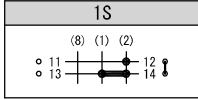
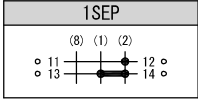
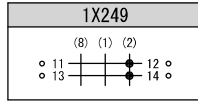
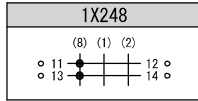
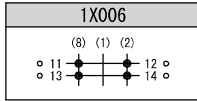
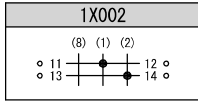
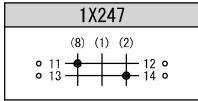
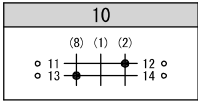

**2 Units**

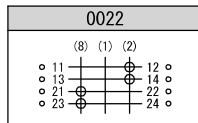
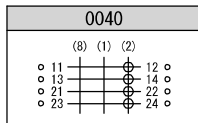
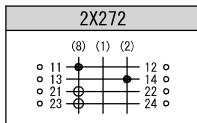
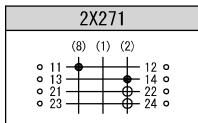
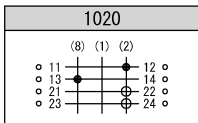
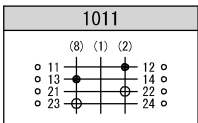
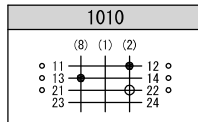
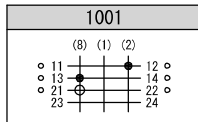
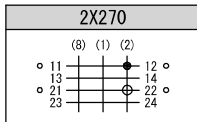
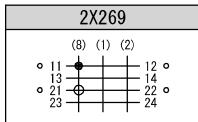
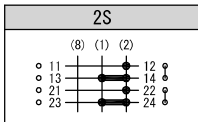
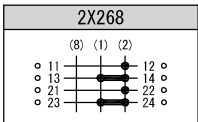
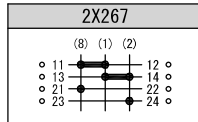
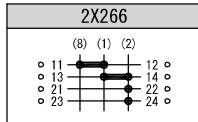
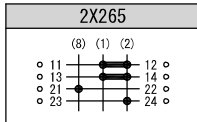
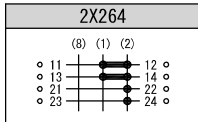
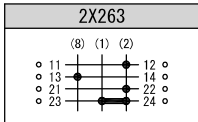
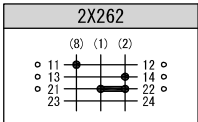
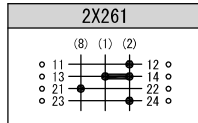
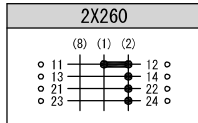
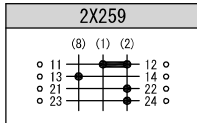
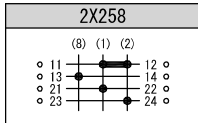
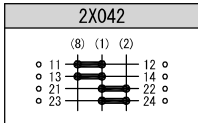
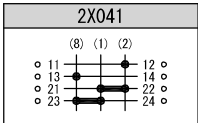
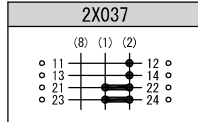
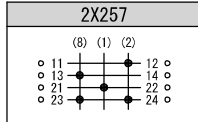
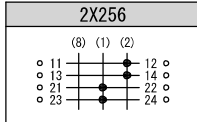
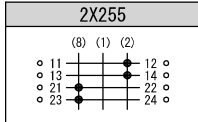
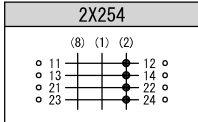
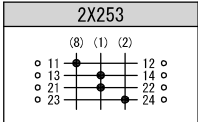
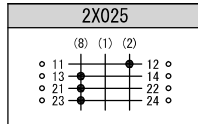
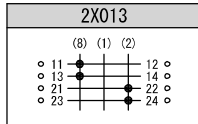
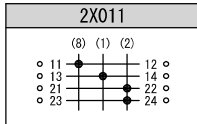
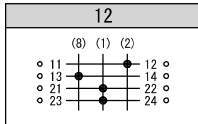
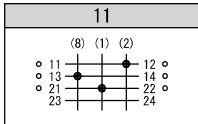
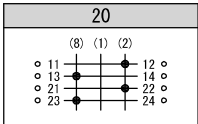

### 3 Units

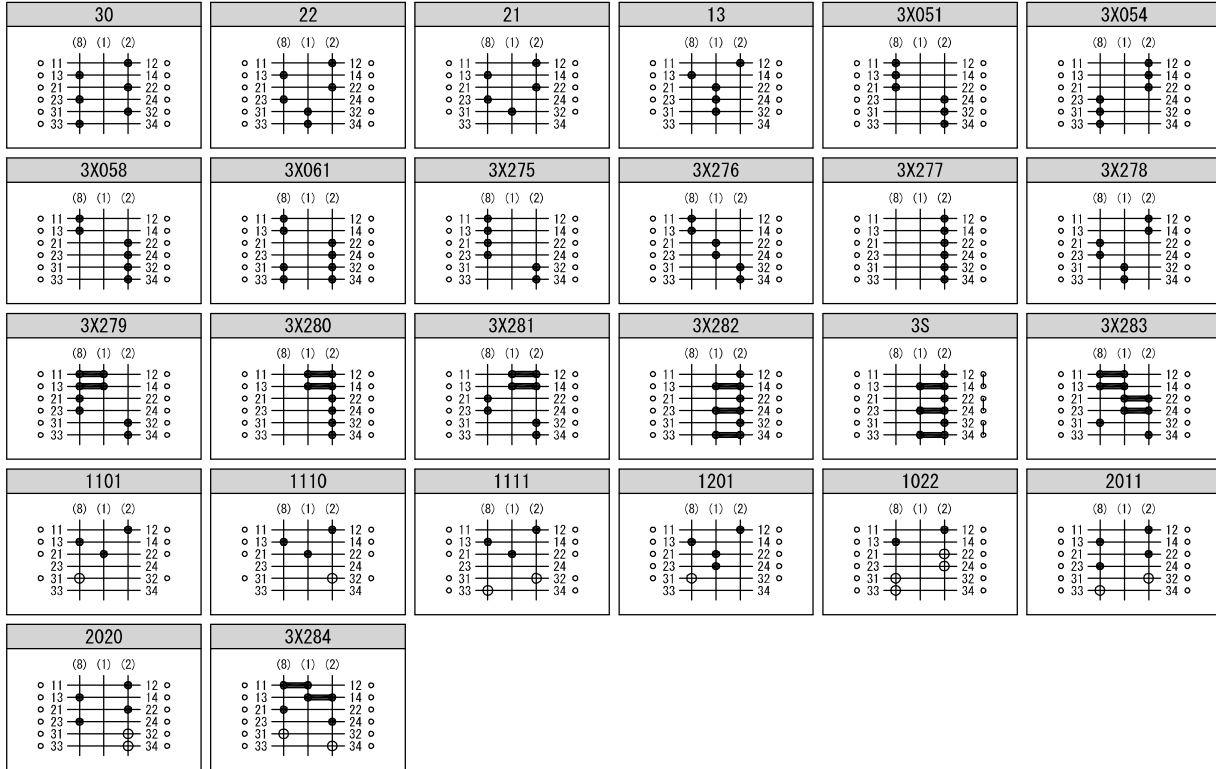

### 4 Units

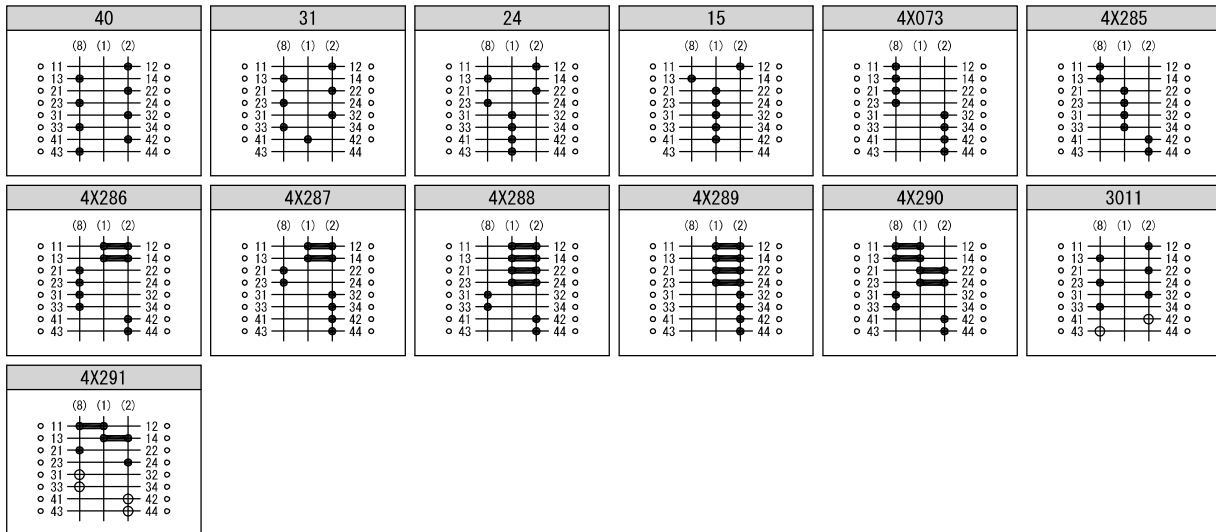

### 5 Units

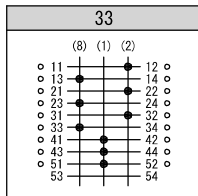

### 6 Units

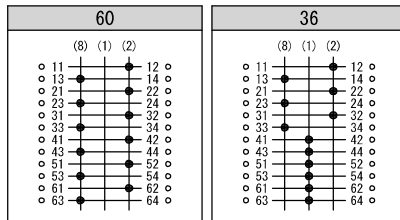

[With PII/Push Contact] Below listed contact diagram's Pull/Push position is 1.

**2 Units**

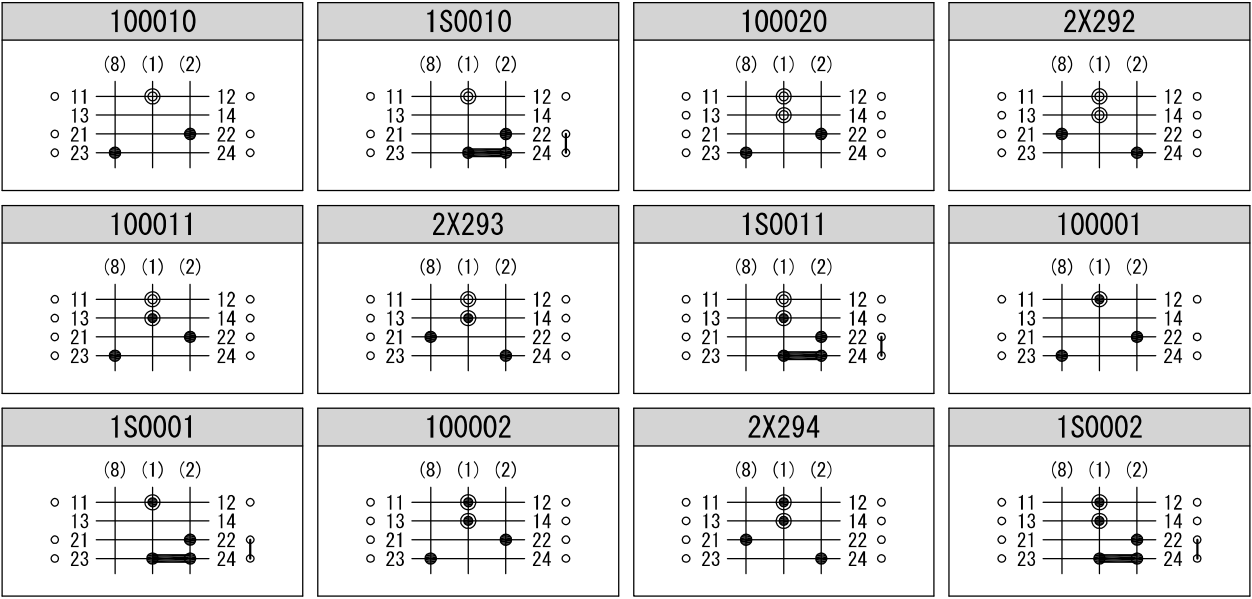

**3 Units**

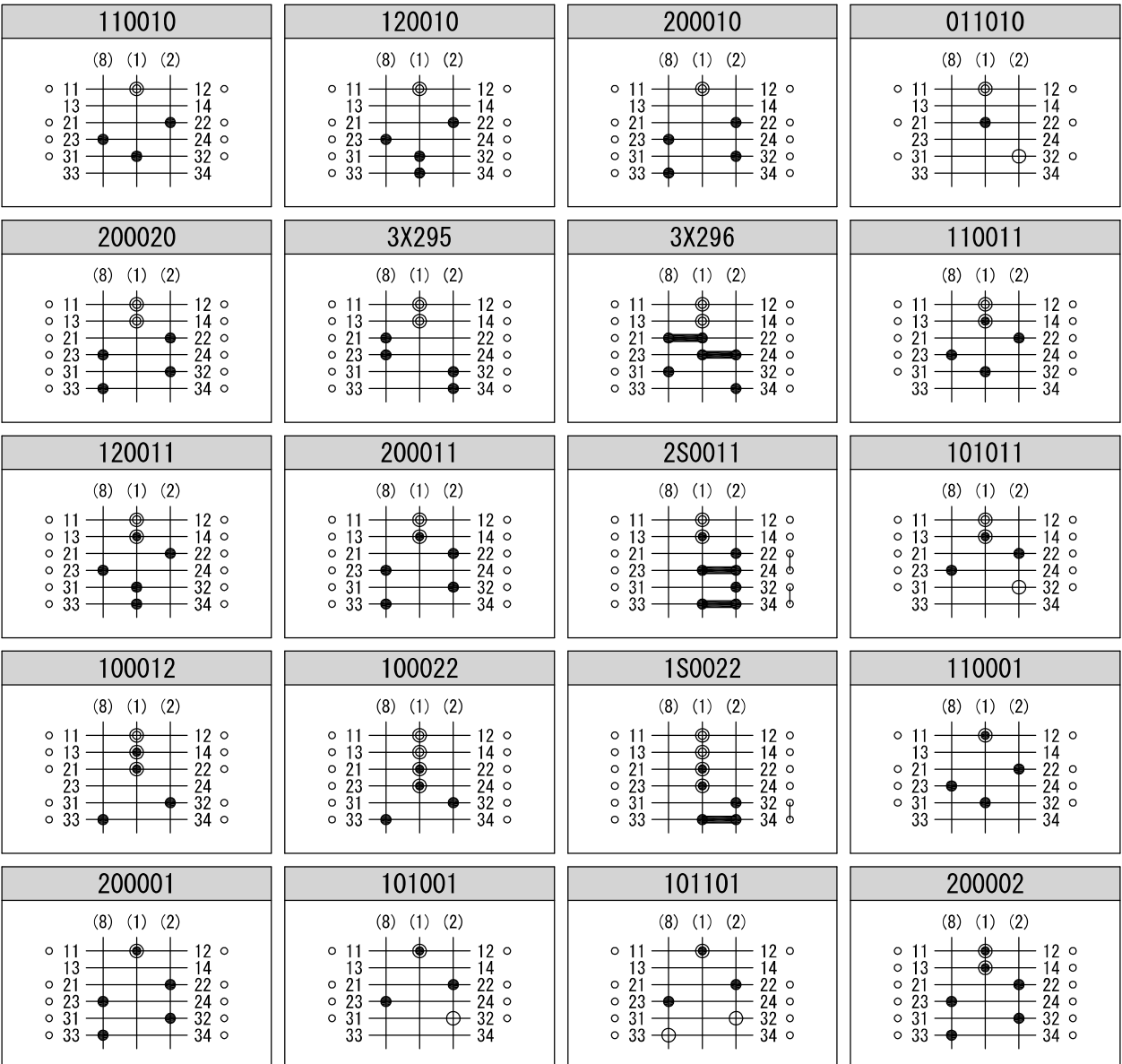



# Order Method of Customized Contact Diagram

Contact Diagram Configuration is composed, as below-illustrated, in the order of Pull/Push Contact, Normal Contact (Single Contact/Continuous Contact), Lap Contact and Residual Contact from the Handle. Therefore, please be sure to write down in the order of Pull/Push Contact, Normal Contact (Single Contact/Continuous Contact), Lap Contact and Residual Contact from the upside when you draw the Contact Diagram.

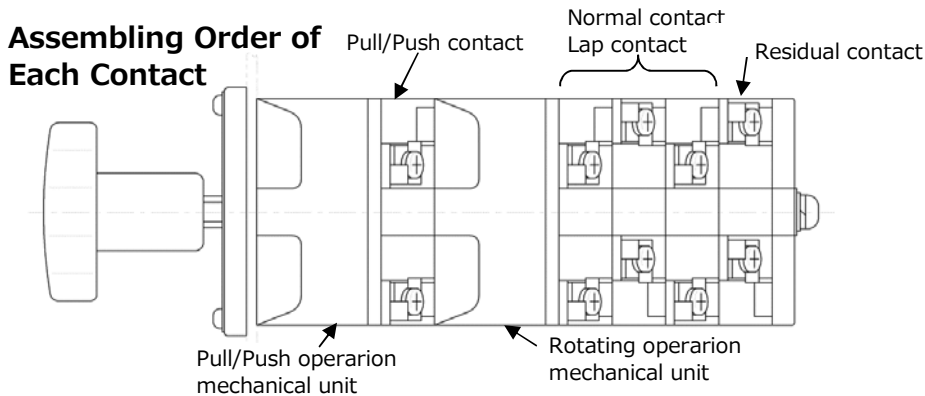

## Describing Order of Each Contact

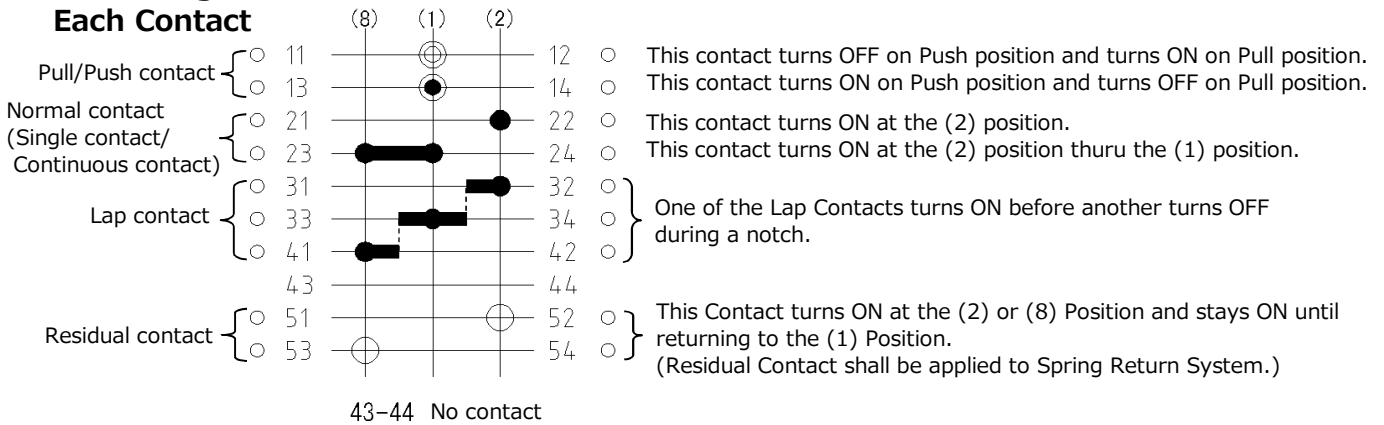

# Instructions & Precautions on Ordering Customied Contact Diagram

## Principles on Unit Combinations

- Single contact and Continuous contact may be combined in same unit. Each of other types of contacts ( Pull/Push, Residual and Lap Contacts) cannot be combined with any of the rest ( other types of contacts) in the same unit. (This is because one (1) cam is used per unit. See Cam List on Pages A-101~103 as for the Contact Combinations Manufacturable.)

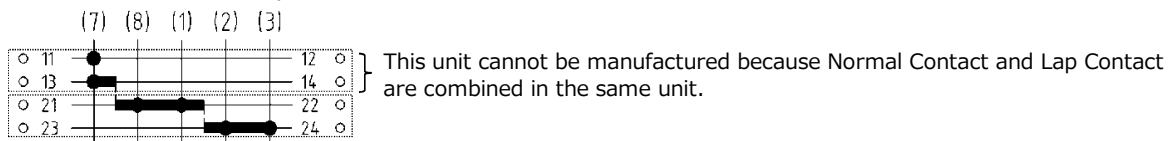

- One (1) Unit Comprises of Contact with two (2) circuits. Because the cam (cam's shape) is positioned at the angle of 180° of a couple of contacts, your requested contact diagram may not be manufactured in one (1) unit. (Especially in case of five (5) notches : 180° or more, two (2) unit shall be configured as shown below.)

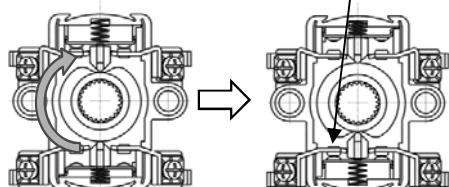
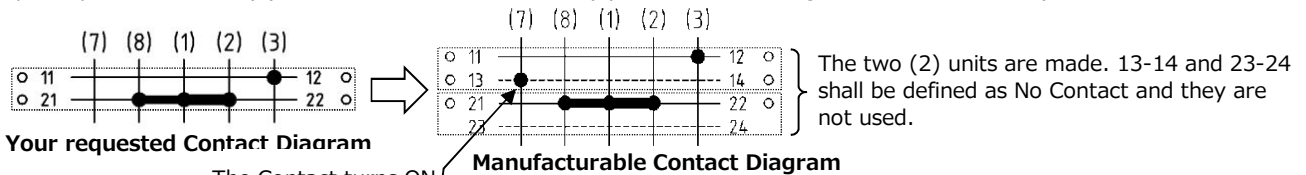

As shown in the left figure, the Cam rotates at 180°, the contact on the opposite side turns ON.

## Operating Angle and Operating Leeway Angle

As for Operating Angle and Operating Leeway Angle of Normal Contact (Single/Continuous Contacts), and Lap Contact, such angles are set as follows for controlling.

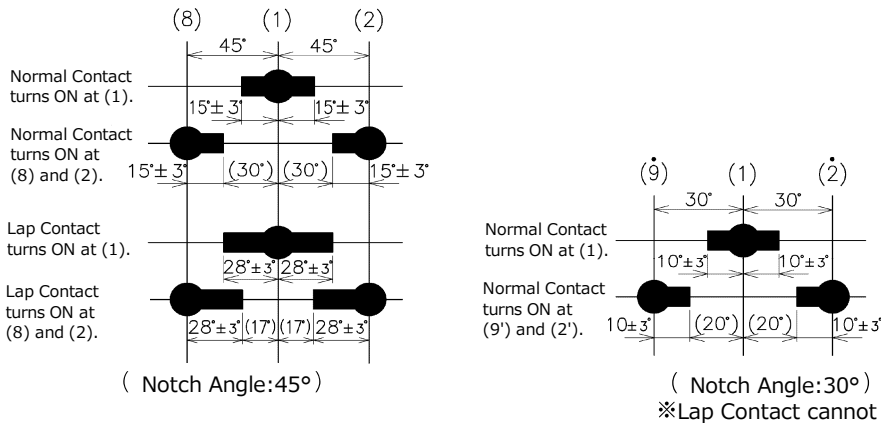

## Precautions on Momentary Lap

As for Single Contact, Continuous Contact and Lap Contact, leeway (allowance) angle of  $\pm 3^\circ$  is set for their respective operation angles. Therefore, in case of the following Contact Diagram in which Single Contact (or Continuous Contact) and Lap Contact coincide, such Contacts may cause a lapping momentarily.

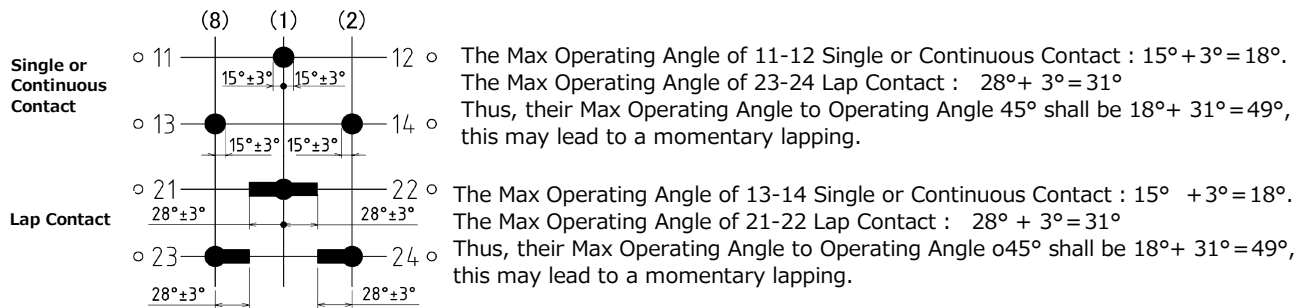

## Max. Number of Units & Max Number of Contacts

### In case of General Type

Operational Methods	Rotating	Manual Return	Spring Return / Complicated Type (※)	Manual Return	Spring Return / Complicated Type (※)	Manual Return	Spring Return / Complicated Type (※)	Click Type
	Pull/Push	-	-	Manual Return	Manual Return	Spring Return	Spring Return	
Max. No. of Units		20	12	16	12	16	12	3
Max. No. of Simultaneous Open Contact		16	6	14	6	14	6	3
Max. No. of Lap Contacts		10	3	8	3	8	2	2
Max. No. of Residual Contacts			6		6		6	
Max. No. of Pull/Push Contacts				6	6	6	6	
Max. No. of Simultaneous Open Pull/Push Contact				6	6	4	4	

### In case of Key Handle Type

Operational Methods	Rotating	Manual Return	Spring Return / Complicated Type (※)
Max. No. of Units		16	12
Max. No. of Simultaneous Open Contact		14	6
Max. No. of Lap Contacts		8	3
Max. No. of Residual Contacts			6

(※) Contact us about the manufacturing of [90° Spring-Return-Type Operation System.]

- Maximum Number of Simultaneously Open Contacts means that the number of contacts, which stay ON at each position and also which are shifting from ON-status to OFF-status in case of rotating operation, is most in number. This Maximum Number of Simultaneous Open Contacts means the maximum number of such type of contact. However, the number of Simultaneously Open Contacts manufacturable in case of Spring-Return means the maximum number of such type of contact in the process of returning to the central position from the left or right position.
- Complicated Type indicates that one side uses Spring Return System and other side uses Manual Return System.
- As for unit integrated with Pull/Push Contact and Residual Contact, They can be manufactured up to three (3) units.
- As for Twin contact, contact us for technical details. This type has fewer contacts due to differences in Contact Pressure Specification.
- Be careful as for Rotating Operation in case of Manual Return, the operation may come to stop on the halfway between the notches. Therefore, be sure to conduct the switchover operation without fail.



CAM List

◆ 45° · 90° Notch CAM

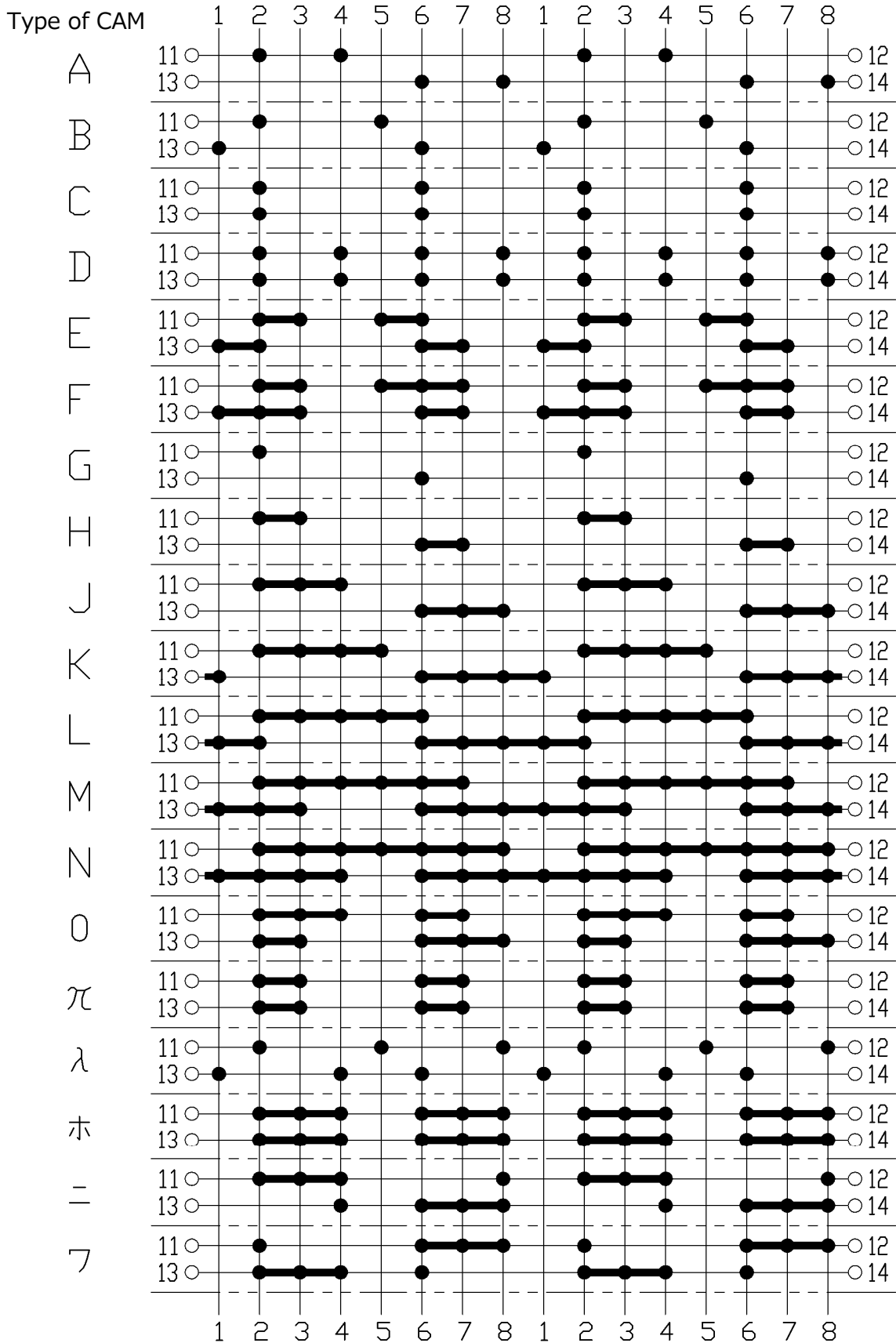

❖ 45° · 90° Notch CAM

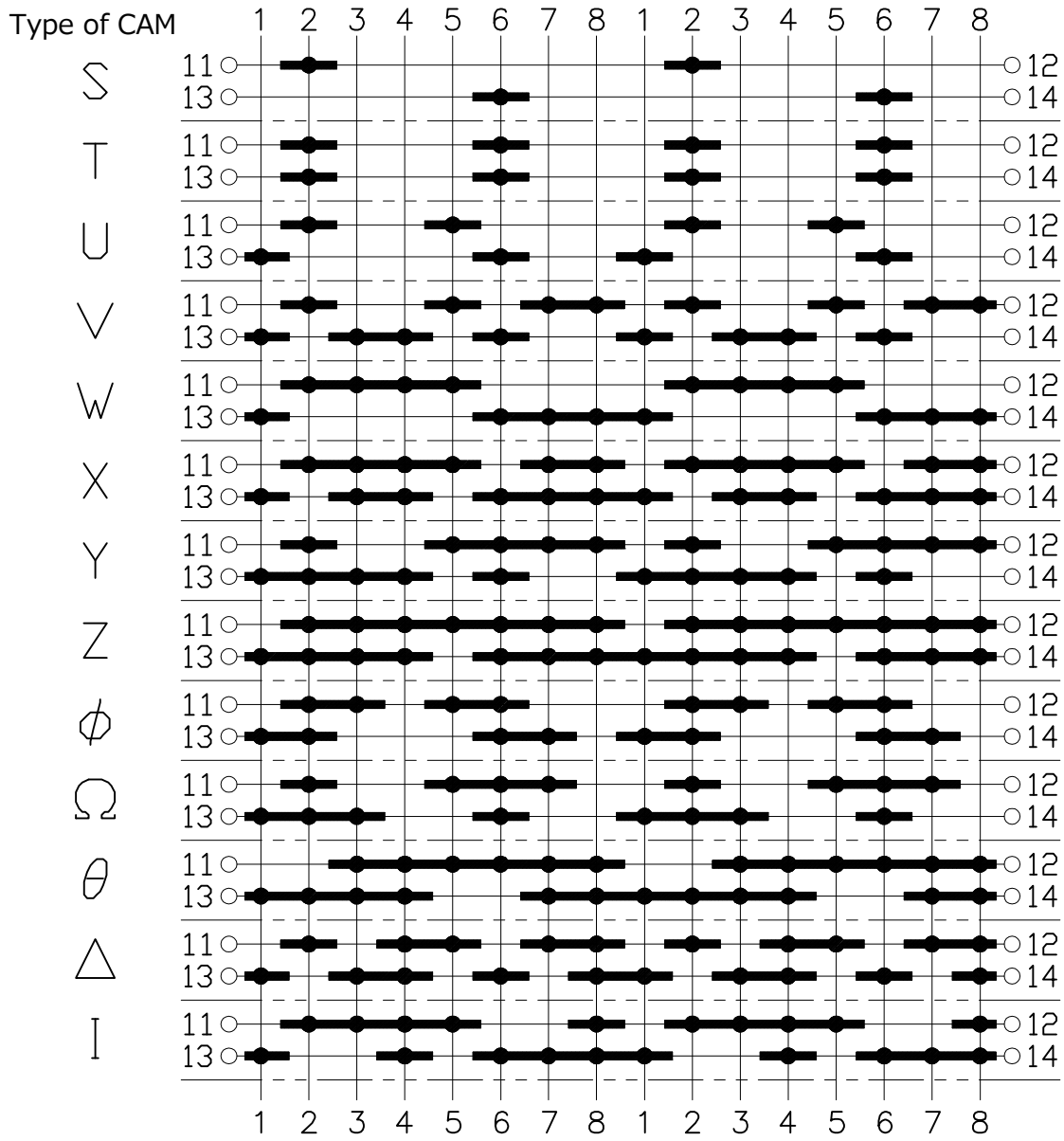



# Part Items

## Terminal Covers

### Side Cover

Model : B - C

Code	Application	Dimensions
S	1~3Units	
L	4~6Units	

※ Side Cover covers from the side of End-Plate to 6th units in case of 7 or more units.  
Choose B-CL in case that Pull/Push contact is integrated.

### Upper Cover

Model : B L C -

Code	Application	Dimensions
S	1~3 Units	
M	4~6 Units L=83	
L	7~9 Units L=119	
LL	10~12 Units L=155	

## Handle Cover

Code	Application Type	Application Handle	Outline		
B-CH1	B-Type	Stick Pistol Oval	Dimentions		
			A	B	C
B-CH2	B-Type	Chrysanthemum Boat Arrow	Dimentions		
			A	B	C
A-CH1	AB-Type	Large Chrysanthemum Large Oval	Dimentions		
			A	B	C
A-CH2 ※	AB-Type	Large Stick Large Pistol	Dimentions		
			A	B	C
JB-CH1	JB-Type	Chrysanthemum Arrow	Dimentions		
			A	B	C
JB-CH2	JB-Type	Stick Pistol Oval	Dimentions		
			A	B	C

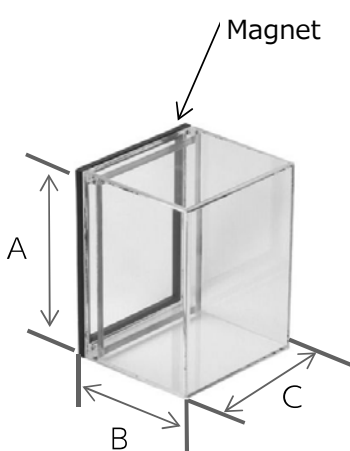

※ Magnet Installation.

※ "A-CH2" can be used for all type of handle in case of YB-Type.

## Handle

Fixing screws are not attached to the Handle, need to order Screw Set shown on Page A-107 separately. Refer to page A-72~73 for the dimension of handles.

Model : B - H   ( )

❖ Key No.(Fill When Key Handle Operation Only)

❖ Handle Color

Code	Color
K	Black(Close to N1.5)
M	Green(Close to 7.5R4.5/14)
R	Red(Close to 7.5BG3/3.5)

KeyNo.	Spec	KeyNo.	Spec
B9	Convex Shape	B8	Concave Shape
B3	Convex Shape (Defferent Pin Position)	B2	Concave Shape (Defferent Pin Position)
B5			
B7			
B1-R	Convex Shape(Clockwise)	B10-R	Concave Shape(Clockwise)
B1-L	Convex Shape(Unclockwise)	B10-L	Concave Shape(Unclockwise)
B2X	Convex Shape (More than 3 Positions)	B3X	Concave Shape (More than 3 Positions)
B8X	Convex Shape(2 Positions)	B9X	Concave Shape(2 Positions)

❖ Standard Size Handle      ❖ Large Size Handle

Code	Shape	Code	Shape
R	Chrysanthemum	AR	Large Chrysanthemum
P	Pistol	AP	Large Pistol
V	Oval	AV	Large Oval
S	Stick	AS	Large Stick
Y	Arrow ※ 1		
F	Boat		

❖ Special Handle(Black Only)

Code	Shape
G	Ball ※ 1,2

※ 1 Arrow Handle, Ball Handle are Black only available. Also these Handles are not available in case of Key Handle Operation.

※ 2 Because of difference of mounting method, Ball Handle cannot be replaced from other shapes of handle.



## Name Plate Stand

Fixing screws are not attached to the Name Plate Stand, need to order Screw Set shown on Page A-107 separately.

Model:  - E

Code	Color
K	Black(Color close to N1.5)
A	Gray Blue(Color close to 7.5BG4/1.5)

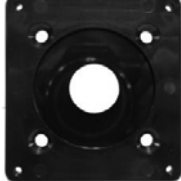
※ Gray Blue Color is not available in case that Basic Type is JB or YB-Type.

Code	B	AB	JB	YB
Measurement	57×52	65×60	56.7×56.7	
Appearance				

## Name Plate Frame

Name Plate Frame for One-Touch mounting type NP. Only for JB-type and YB-type available.(Black Color only)

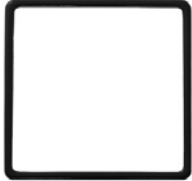
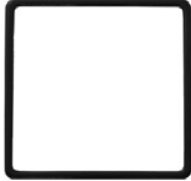
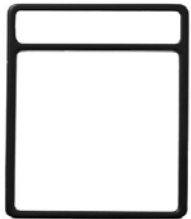
Code	JB-FJK	JB-FJK(S10)	YB-FK
Application	JB-Type(NP Thickness:0.5mm) (For Alminius/Stainless NP)	JB-Type(NP Thickness:1.0mm) (For Acrylic NP)	YB Type
Measurement	60×60	60×60	73×60
Appearance			

## Name Plate

Fixing screws and Indicator are not attached to the Name Plate, need to order Screw Set shown on Page A-107 separately.

Model:  - N

(W)

### ❖ Option(Indicator/Key Handle)

Code	Spec
Nothing Filled	Standard
(W)	w/t Indicator Hole
(K)	For Key Handle(φ15)

※ Indicator is not available in case that Basic Type is AB-Type or YB-Type or Acrylic NP.

※ Choose Key No. from Page A-69~70.

### ❖ Name Plate Letters

Code	Spec	Remarks
0	Blank	
X	To inscribe Customized Letters	Fill your desired Letters in the Order Sheet on Page A-114~117.
<input type="checkbox"/> <input type="checkbox"/> <input type="checkbox"/>	Pre-Printed NP	Choose your desired Letter No. from NP List on Page A-77.

### ❖ Material

Code	Material	Thickness(mm)
Nothing Filled	Standard Aluminium NP(Screen+Baking Clear Coating)	0.5
S	Stainless Name Plate(Delustering Polish)	0.5
A	Acrylic Name Plate(Backside's Inscription Letter Color: Black)	1.0

※ Acrylic Name Plate is not available in case that Basic type is YB-Type.

### ❖ Basic Type

Code	Basic Type
B	B-Type
AB	AB-Type
JB	JB-Type
YB	YB-Type

## Indicator

Model : B-T1

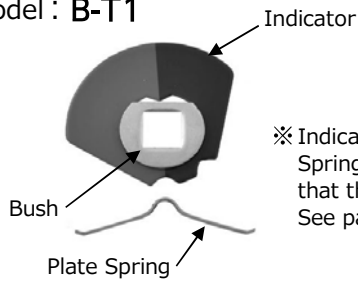

※ Indicator can be additionally mounted only when Operation method is Spring-Return-Type(Operational Angle45°). Indicator cannot be mounted in case that the basic type is AB-Type and YB-Type, and in case that Acrylic Name Plate is used. See page A-112 for Assembly Method.

## Short Bar

Code	B-J1	B-J2	B-J3
Terminal No.	11-13 · 22-24 · 31-33 · 42-44	12-14 · 21-23 · 32-34 · 41-43	11-21 · 13-23 · 31-41 · 33-43
	51-53 · 62-64 · 71-73 · . . . . .	52-54 · 61-63 · 72-74 · . . . . .	51-61 · 53-63 · 71-81 · . . . . .
Shape			
Code	B-J4	< Usage Example >	
Terminal No.	12-22 · 14-24 · 32-42 · 34-44		
	52-62 · 54-64 · 72-82 · . . . . .		
Shape			

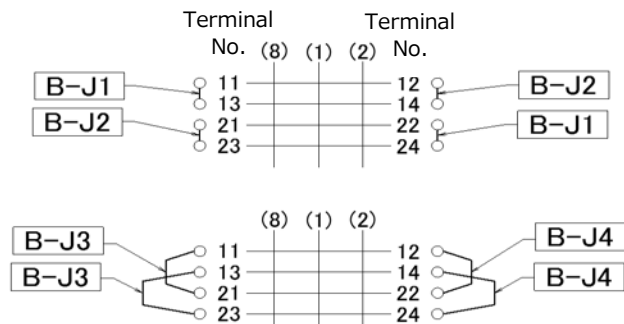

## Screw Set

Set sales only. Not sold separately.

Model : B - B

Code	Application Model	Set including	Screw Type	Materials	
1	B-Type	For Handle	M3×10 1 pc	Built in Round Head Screw(3P)	Copper(Glvanized)
		For NP	M2.6×5 4 pcs	Round Head Tappng Screw	Brass(Nickel-Plated)
		For NP Stand	M4×16 4 pcs	Countersunk Screw	Copper(Glvanized)
5	AB-Type	For Handle	M3×10 1 pc	Built in Round Head Screw(3P)	Copper(Glvanized)
		For NP	M3×5 4 pcs	Round Head Tappng Screw	Brass(Nickel-Plated)
		For NP Stand	M4×16 4 pcs	Countersunk Screw	Copper(Glvanized)
13	JB-Type YB-Type	For Handle	M3×10 1 pc	Built in Round Head Screw(3P)	Copper(Glvanized)
		For NP	—	—	—
		For NP Stand	M4×16 2 pcs	Built in Round Head Screw(3P)	Copper(Glvanized)

# Outline Drawing

※ See A-111 for dimension of respective handle.

**Manual Return/Spring Return/Hybrid**

Type: BN, BR□, BNR□/ABN, ABR□, ABNR□

[NP unit Size]

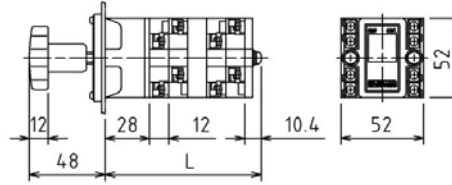
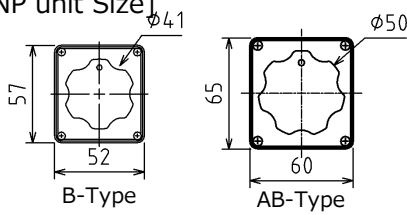

[Mounting Hole size]

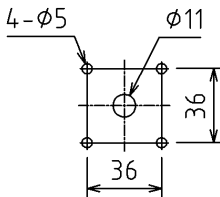

No. of units	1	2	3	4	5	6	7	8	9	10
L(mm)	50	62	74	86	98	110	122	134	146	158
No. of units	11	12	13	14	15	16	17	18	19	20
L(mm)	170	182	194	206	218	230	242	254	266	278

※ Spring Return and Hybrid type can be manufactured up to 12 Units.

**Manual Return/Spring Return/Hybrid**

Type: JBN, JBR□, JBNR□/YBN, YBR□, YBNR□

[NP unit Size]

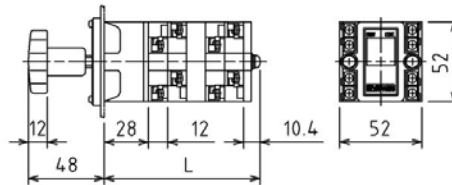
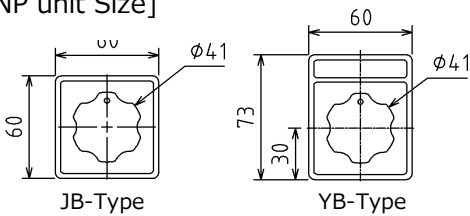

[Mounting Hole size]

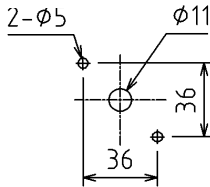

No. of units	1	2	3	4	5	6	7	8	9	10
L(mm)	50	62	74	86	98	110	122	134	146	158
No. of units	11	12	13	14	15	16	17	18	19	20
L(mm)	170	182	194	206	218	230	242	254	266	278

※ Spring Return and Hybrid type can be manufactured up to 12 Units.

**Pull·Push operation  
(w/o pull·push contact)  
/Spring Return w/ Click**

Type: BNP□, BRP□, BNR□□, BNS□, BRS□, BNR□S□,  
BNT□, BRT□, BNR□T□  
ABNP□, ABRP□, ABNR□□, ABNS□, ABRS□, ABNR□S□  
ABNT□, ABRT□, ABNR□T□, BRX, ABRX

[NP unit Size]

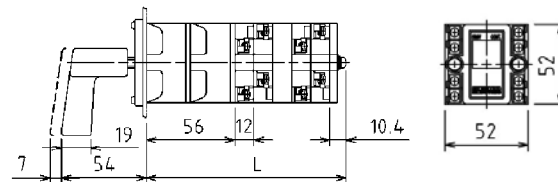
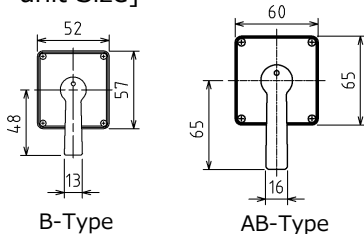

[Mounting Hole size]

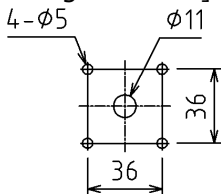

No. of units	1	2	3	4	5	6	7	8	9	10
L(mm)	78	90	102	114	126	138	150	162	174	186
No. of units	11	12	13	14	15	16				
L(mm)	198	210	222	234	246	258				

※ In case that Rotating operation is Spring Return or Hybrid type can be manufactured up to 12 Units. Click Type w/ click can be manufactured up to 3 units.



**Pull·Push operation  
(w/o pull·push contact)  
/Click type Spring Return**

Type: JBNP□, JBRP□, JBNR□P□, JBNS□, JBRS□, JBNR□S□  
JBNT□, JBRT□, JBNR□T□  
YBNP□, YBRP□, YBNR□P□, YBNS□, YBRS□, YBNR□S□  
YBNT□, YBRT□, YBNR□T□, JBRX, YBRX

[NP unit Size]

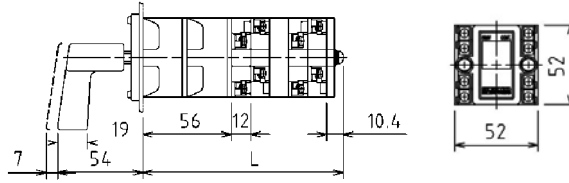
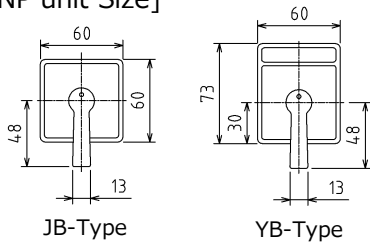

[Mounting Hole size]

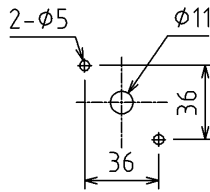

No. of units	1	2	3	4	5	6	7	8	9	10
L(mm)	78	90	102	114	126	138	150	162	174	186
No. of units	11	12	13	14	15	16				
L(mm)	198	210	222	234	246	258				

※In case that Rotating operation is Spring Return or Hybrid type can be manufactured up to 12 Units.Click Type w/ click can be manufactured up to 3 units.

**Pull·Push operation  
(w/ pull·push contact)**

Type : BNP□, BRP□, BNR□P□, BNS□, BRS□, BNR□S□,  
BNT□, BRT□, BNR□T□  
ABNP□, ABRP□, ABNR□P□, ABNS□, ABRS□, ABNR□S□  
ABNT□, ABRT□, ABNR□T□

[NP unit Size]

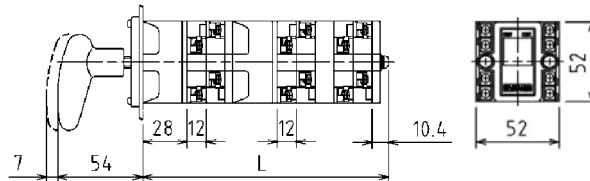
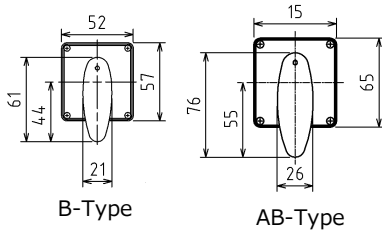

[Mounting Hole size]

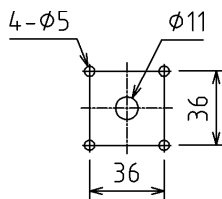

No. of units	1	2	3	4	5	6	7	8	9	10
L(mm)	-	96	108	120	132	144	156	168	180	192
No. of units	11	12	13	14	15	16				
L(mm)	204	216	228	240	252	264				

※In case that Rotating operation is Spring Return or Hybrid type can be manufactured up to 12 Units.

**Pull-Push operation  
(w/ pull-push contact)**

Type: JBNP□, JBRP□, JBNR□P□, JBNS□, JBRs□, JBNR□S□  
 JBNT□, JBRT□, JBNR□T□  
 YBNP□, YBRP□, YBNR□P□, YBNS□, YBRs□, YBNR□S□  
 YBNT□, YBRT□, YBNR□T□

[NP unit Size]

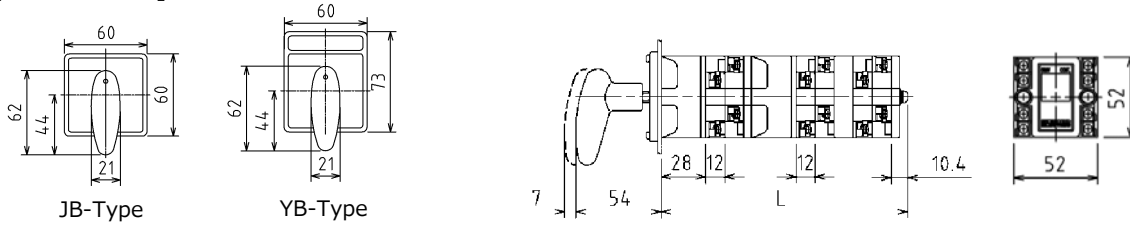

[Mounting Hole size]

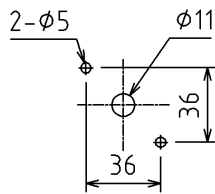

No. of units	1	2	3	4	5	6	7	8	9	10
L(mm)	-	96	108	120	132	144	156	168	180	192
No. of units	11	12	13	14	15	16				
L(mm)	204	216	228	240	252	264				

※In case that Rotating operation is Spring Return or Hybrid type can be manufactured up to 12 Units. Click Type w/ click can be manufactured up to 3 units.

**Key Handle Type**

Type : BNK□, BRK□, BNR□K□/ABNK□, ABRK□, ABNR□K□

[NP unit Size]

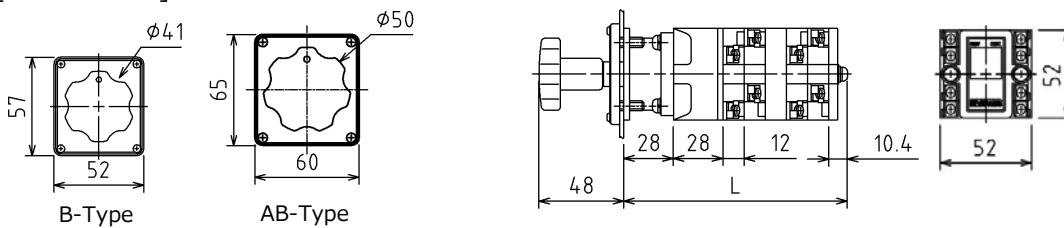

[Mounting Hole size]

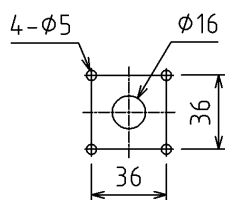

No. of units	1	2	3	4	5	6	7	8	9	10
L(mm)	78	90	102	114	126	138	150	162	174	186
No. of units	11	12	13	14	15	16				
L(mm)	198	210	222	234	246	258				

※Spring Return and Hybrid type can be manufactured up to 12 Units.

**Key Handle Type**

Type : JBNK□, JBRK□, JBNR□K□/YBNK□, YBRK□, YBNR□K□

[NP unit Size]

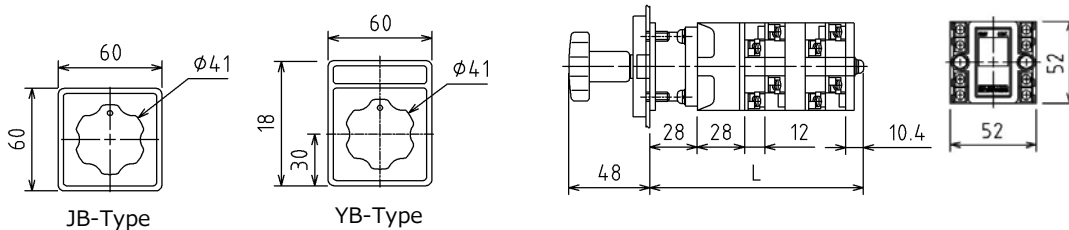

[Mounting Hole size]

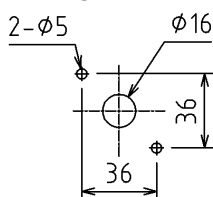

No. of units	1	2	3	4	5	6	7	8	9	10
L(mm)	78	90	102	114	126	138	150	162	174	186
No. of units	11	12	13	14	15	16				
L(mm)	198	210	222	234	246	258				

※Spring Return and Hybrid type can be manufactured up to 12 Units.

# Handle Dimensions(Mounted Condition)

[Remarks]

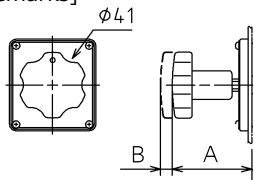

A: Dimension from the mounting surface of Mechanical unit of Switch to the End of Handle.  
 B: Length of Handle Pulled out when Pull Operation.

\*Broken Line Drawings are image of Pull/Push Operation.

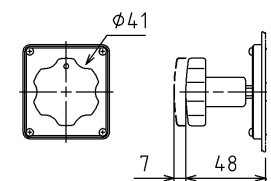
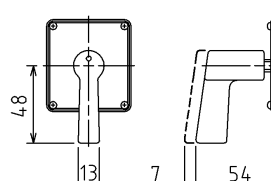
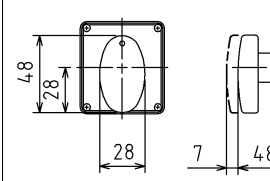
Shapes	Chrysanthemum	Pistol	Oval
Code	R	P	V
Dimensions			

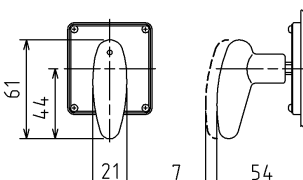
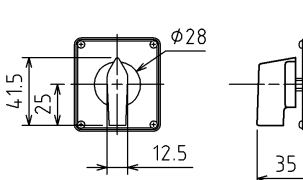
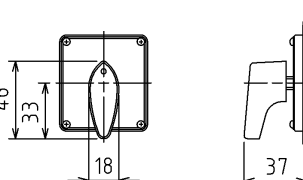
Shapes	Stick	Arrow	Boat
Code	S	Y	F
Dimensions			

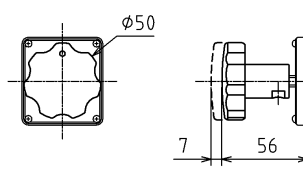
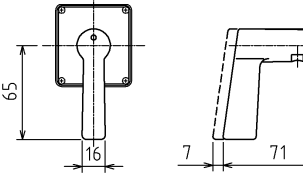
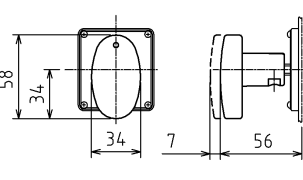
Shapes	Large Chrysanthemum	Large Pistol	Large Oval
Code	AR	AP	AV
Dimensions			

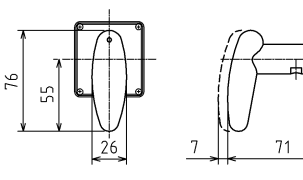
Shapes	Large Stick
Code	AS
Dimensions	

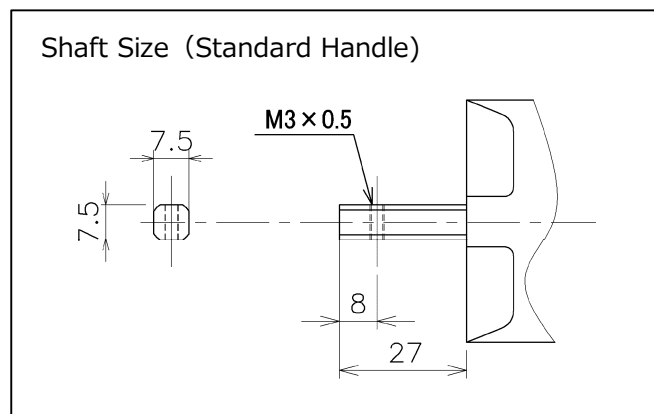

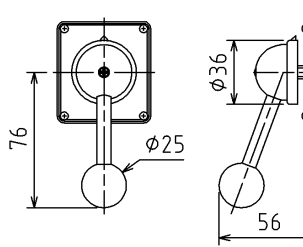
Shapes	Ball
Code	G
Dimensions	

# Mounting Hole Processing Dimensions and Assembly Method

B·AB-Type screwing NP 【Mounding Method】	JB·YB-Type One-Touch NP 【Mounding Method】
<p>【Mounting Hole Shape】</p>	<p>【Mounting Hole Shape】</p>

B-Type w/ Indicator 【Mounding Method】	JB-Type w/ Indicator 【Mounding Method】
<p>Be careful with its direction!</p>	<p>Be careful with its direction!</p>
<p>【Mounting Hole Shape】</p>	<p>【Mounting Hole Shape】</p>

## ● Standard Torque of Screws of Each Type

Screw Type	Screw Size	Tightening Torque
NP Mounting Screw	M2.6	0.3N·m {3kgf·cm}
	M3	0.4N·m {4kgf·cm}
Handle Fixing Screw	M3	0.7N·m {7kgf·cm}
Terminal Screw	M3.5	0.8N·m {8kgf·cm}
NP Stand Mounting Screw	M4	1.0N·m {10kgf·cm}

# Technical Reference

## Name of Each Parts and its Materials

	SYM. No.	Parts Name	Materials	Plating / Flame Resistance
	1	Handle	ABS Resin	UL94 HB
	2	NP Stand	ABS Resin	UL94 HB
	3	Name Plate	Aluminium	—
	4	Shaft	Steel/Zinc Die-Cast	Galvanized
	5	Mechanical Case	PBT Resin	UL94 V-0
	6	Stopper Plate	ABS Resin	UL94 HB
	7	Contact Base	PBT Resin	UL94 V-0
	8	End Plate	PBT Resin	UL94 V-0
	9	Window	Polyvinyl Chloride Resin	UL94 V-2
	10	Cam	Polyacetal Resin	UL94 HB
	11	Movable Contact	Brass	Nickel-Plated
	12	Fixed Contact	Brass	Nickel-Plated
	13	Contact	Silver/Copper	—
	14	Contact Spring	Stainless Steel	—
	15	Terminal Screw	Copper	Galvanized
	16	Bracket	Nylon Resin	UL94 V-2
	17	Notch Lever	Polyacetal Resin	UL94 HB
	18	Push Spring	Stainless Steel	—
	19	Roller	Brass	—
20	Notch	Polyacetal Resin	UL94 HB	

## Weight List

The weight listed below stands for roughly calculated weight of [Main Body of a switch + NP stand + Name Plate + Handle + A set of screws used].

The number of the units manufacturable is limited depending on the types.

See page A-100 for the number of the units manufacturable.

(g)

Number of Unit	Rotating Operation	Pull/Push Operation· Click-Type
1	250	350
2	300	400
3	350	450
4	400	500
5	450	550
6	500	600
7	550	650
8	600	700
9	650	750
10	700	800
11	750	850
12	800	900
13	850	950
14	900	1,000
15	950	1,050
16	1,000	1,100
17	1,050	
18	1,100	
19	1,150	
20	1,200	