

RT100

Programming Manual



SOF1130

Documentation RT100 Control System

This manual is copyrighted. Unauthorised duplication is prohibited by law. To the best of our knowledge and belief, the information contained in this manual is true and correct as of the date of publication. The contents, however, do not constitute a binding obligation on the part of Regloplas AG and are subject to change without notice.

© Copyright 2013 Regloplas AG

All rights reserved

Printed in Switzerland

**Regloplas AG
Flurhofstrasse 158
9006 St. Gallen
Switzerland**

Tel.: +41-71-282 58 00

Fax: +41-71-282 58 40

E-mail: info@regloplas.com

Homepage: www.regloplas.com

Contents

General Safety Information	1
Safety Symbols	1
Range of Application	2
Intended Use	2
Safety Information	2
General Information	2
Process Monitoring	2
Information for Operators and Personnel	3
Changing the Parameterisation	3
Residual Risks	3
Using this Documentation	4
Additional Documentation	4
Design and Function	5
Range of Application	5
Software Version	5
RT100 Control System - Hardware	5
Construction	5
Operation Concept	5
Operating Control and Display Elements	6
Buttons	6
Status LEDs	6
Device Functions	6
Symbols	7
RT100 Control System - Displays	7
Operation and Status Displays	7
Setting the Set-points	7
Parameter Menu	8
RT100 Control System - Functions	8
Powering Up	8
Power Down	8
Leak-stop operation	8
Draining	9
Operation with Code/Password	10
Operation with Timer	10
Alarm Reset and Alarm History	10
Save/Reset of the Setting Values	10
RT100 Control System - Loading firmware/bootloader	11
USB flash drive	11
Loading the firmware/bootloader	12
RT100 Control System - Activating Options	12
Software options	12
Technical Data	15
RT100 Control System	15
General Data	15
Electrical Data	15
Inputs	16







Outputs	16
Data Interfaces (Option)	16
Display	16
Precision	17
Operation	17
Dimensions	17
Parameterisation	19
General	19
Show actual values	19
Select language	20
User settings	20
Display	20
Clock	20
Switch clock	20
Ramp program (Software option)	21
Set-point	22
Evacuation time	22
Next Service	23
Pump regulation	23
USB Logging (Service Interface)	23
Monitoring	23
Temperature deviation	23
Max. heat./cool. time	24
Minimum flow rate	24
Flow deviation (Software option)	24
Min. system pressure	25
Interfaces	25
Address	25
Temperature control	25
Temperature Regulation	25
Control parameters outlet	25
Control parameters cascade	26
Settings	26
Control system modes	26
Fixed parameter sets	26
Pressure control	27
Pump regulation (Software option)	28
Unit configuration	28
Inputs	30
Flow meter type F1000 (Software option, max. 300 lpm)	31
Outputs	33
Relay	34
Collective alarm	35
Save/Load	37
Code	37
Options	38
Current monitoring heating	39
Service menu	39
Multiflow	39
Data Interfaces	41
Basic Concept	41
Protocols	41
Plug Nomenclature	43
RT100 Front panel	43
RT100 Base Module	43

RT100 Digital Option.....	46
Digital Functions	46
Relay Functions	46
RT100 Analog Option	46
Digital Functions	46
Analog Functions	47
RT100 Option Reversal of Direction of Rotation >9A.....	47
RT100 Option Current Monitoring Heating	47
RT100 Option Multiflow (connection).....	48
Hardware	49
RT100 Front Panel - Layout.....	49
RT100 Base Module - Layout	50
Analog Option - Layout	51
Digital Option - Layout	52
Option Reversal of Direction of Rotation >9A - Layout.....	53
Option Current Monitoring Heating - Layout	53
Option Profibus DP - Layout	54
Option Euromap 66 - Layout.....	55
Option Profinet-IO - Layout.....	56
Option Multiflow - Layout	57
Fault Rectification	59
Alarm Messages	59
Alarm List	59
Warnings.....	59
Alarms.....	60
System Errors/System Notes.....	61
RT100 Control System - Maintenance/repair	63
Replacing the front panel.....	63
Removal	63
Installation.....	63
Loading the firmware	63
Replacing the base module	64
Removal	64
Installation.....	64
Hardware checklist.....	64
Loading the firmware	64
Activating options.....	64
Loading the factory settings.....	65
Configuration check	65
Customer-specific settings.....	65
CAN terminating resistors and address settings.....	66
Spare Parts	69
Ordering Spare Parts	69
RT100 Control System - Spare Parts	70



General Safety Information

Safety Symbols

 DANGER	
	Denotes imminent danger. Failure to heed the information can result in death or grave personal injury (disability)!
 WARNING	
	Denotes a dangerous situation. Failure to heed the information can result in death or grave personal injury (disability)!
 CAUTION	
	Denotes a potentially dangerous situation. Failure to heed the information can result in property damage as well as minor or moderate personal injury!
NOTE	
	Denotes general information, useful advice to users and work recommendations, which, however, do not have any influence on the safety and health of personnel.

Range of Application

This general safety information is generally valid for all temperature controllers and control systems from Regloplas.

Intended Use

The Regloplas control system is built according to the current state of the art and the generally accepted principles of safety engineering. The control system is intended solely for the normal use for heating and/or cooling of injection and die casting moulds, extruders, calenders, mixers and other consumers in areas in which there is no risk of explosion.

Any use beyond this shall be deemed to constitute improper use. The manufacturer is not responsible for damage resulting from improper use; the user is solely responsible for such risks. The control system may not be used under other operating conditions and/or with other media, in deviation from our specifications, without the prior consent of Regloplas AG.

Use as intended also entails compliance with the operating, servicing and maintenance conditions stipulated by the manufacturer. The control system may only be operated, serviced and maintained by personnel who are familiar with these tasks and have been instructed as to the risks.

Safety Information

General Information

The Regloplas control system is safe to operate, but this device can pose danger to life and limb if it is used incorrectly or for a purpose other than that intended. It should be noted that this poses risks to the life and limb of the user or third parties, adverse effects on the equipment and other material assets belonging to the user, and risks to the efficient operation of the equipment.

Start-up (i.e., commencement of intended use) is prohibited until it has been determined that the control system has been set up and wired in accordance with the Machinery Directive (2006/42/EC). EN 60204-1 (Safety of Machinery) must also be observed.

These operating instructions must be read carefully before turning on and operating the temperature control unit. The information regarding the intended use and foreseeable misuse must be observed. Local safety regulations must also be obeyed.

If the control system is used in combination with products by other manufacturers, their notices and safety regulations must also be obeyed.

Process Monitoring

In plants in which a temperature control system malfunction leads to endangerment of the operating personnel or destruction of the plant, an independent process monitor that shuts down the plant securely must be used.

Information for Operators and Personnel

The operator and all persons who are tasked with working on the temperature control unit must obey the fundamental regulations regarding work safety and accident prevention. The operator must ensure that only persons who have read and understood these operating instructions, particularly the chapter on safety, work on the temperature control unit.

Any working methods that have a negative effect on the technical safety of the temperature control unit must not be used. The operator must ensure that the temperature control unit is operated only in flawless condition. If necessary, the company using the equipment must obligate the operating personnel to wear protective clothing.

For all tasks having to do with set-up, start-up, operating, modification of operating conditions and operational modes, maintenance, inspection and repair, any shut-down procedures stated to be necessary in the operating instructions must be followed.

Changing the Parameterisation

The parameterisation of the control system may only be carried out by personnel trained by Regloplas. In particular, no parameters in the device configuration may be changed without consulting Regloplas.

The relevant accident prevention regulations and the generally accepted principles of safety engineering, occupational medicine and structural engineering must be observed. The national safety regulations must also be obeyed.

Residual Risks

Any unauthorised modifications and changes to the temperature control device as also unauthorised changes to the parameterisation of the control system are prohibited for reasons of safety.

If the temperature control unit is damaged, it must not remain in use; the defective part must be replaced or repaired immediately. Only original Regloplas replacement parts may be used. Damage due to use of third-party parts voids any and all warranty claims.



DANGER



The temperature control unit must be disconnected before it is opened (unplug mains plug or, if present, turn the yellow/red main switch on the temperature control unit)! Danger due to electrical shock!

Repair leaks in the temperature control circuit (device, connecting lines, consumers, etc.) immediately.

In temperature control units that use oil as a heat transfer medium, it should be noted that oil is flammable under certain conditions. For this reason, the temperature control unit must not be located in the vicinity of heat sources. The thermal insulation in the device must always be kept clean. Insulation that is soaked with thermal oil poses an increased risk of fire.

Burning thermal oil can be extinguished using a spray foam fire extinguisher, a powder fire extinguisher (avoid with dust-sensitive plants, control systems, EDP, etc.) or a CO₂ fire extinguisher. The appropriate fire

extinguisher must be provided by the operator, taking into account the equipment located in the room and the mandatory safety regulations.

The temperature control unit may only be operated when all safety systems are completely installed and intact.

The temperature control unit must be protected against sprays and cleaning agents.

Before detaching connecting lines in the temperature control circuit and depending on the outlet temperature, allow the temperature control device to cool down first and then turn it off. Check that the pump is no longer running.

 WARNING	
	Important - danger of injury in the event of escaping water or oil!

Using this Documentation

This documentation contains important information for safe, economical operation and for proper maintenance of the device.

Compliance with this documentation helps to avoid danger, minimise repair costs and downtime, and increase the dependability and service life of the device/system.

NOTE	
	The operating instructions should be kept near the corresponding device/system and always be accessible to operating and maintenance personnel.

Additional Documentation

The included instructions are completely correct for the basic versions of devices. Components that do not belong to the basic hardware are noted in the instructions as extra equipment. The corresponding additional documents are included with special versions of devices. Any additional documents supplement and/or replace the descriptions contained in these instructions, which are then either invalid or only conditionally valid.

Design and Function

Range of Application

The RT100 Control System has been developed for the control and operation of Regloplas temperature control units and in addition, facilitates connection to a superordinate control system of a production plant.

Software Version

NOTE



The following description of the RT100 Control System and its parameterisation is valid beginning with software version 1130.

RT100 Control System - Hardware

Construction

The microprocessor-controlled RT100 Control System from Regloplas consists of a front panel (operation and display section) and a base module (power section).



CAUTION



No external, third-party devices may be connected to the 24 VDC supply and the AC supply of the base module!

Operation Concept

The RT100 Control System is equipped with an RCD control knob. It can be used for navigation in the user interface through simple rotating and pressing.





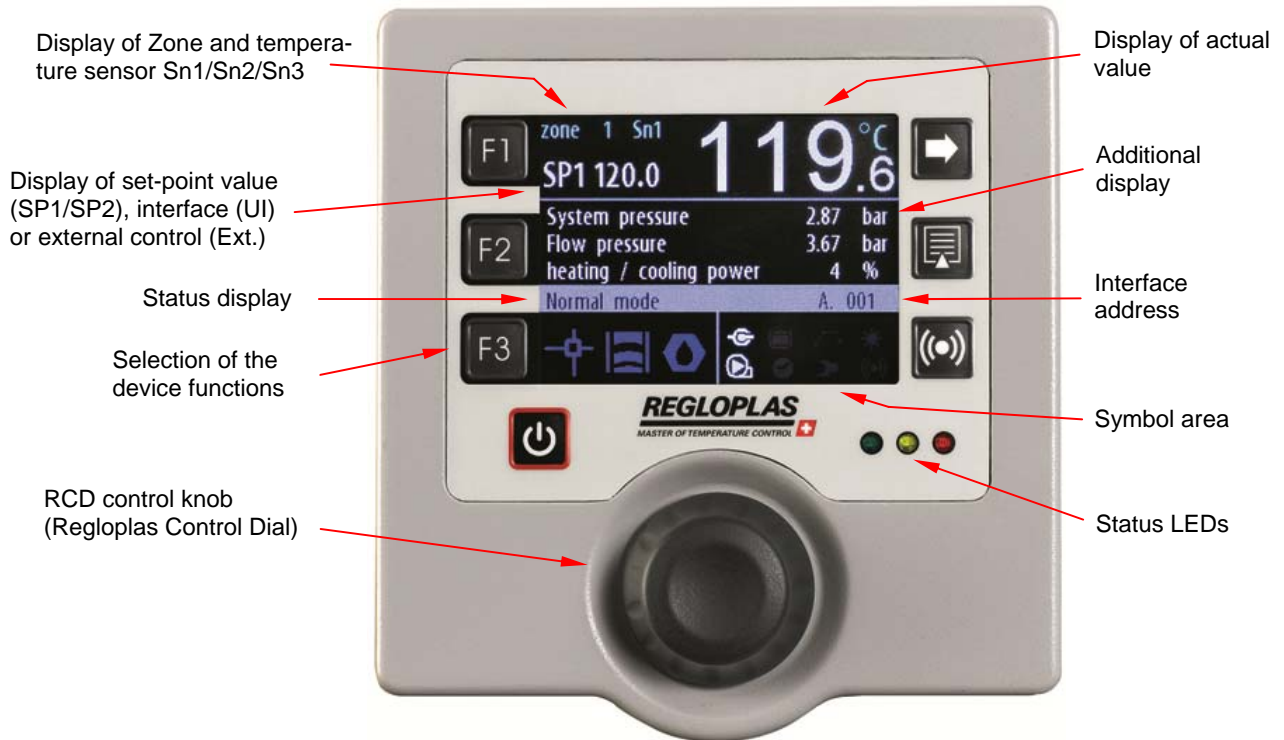

Pressing once selects a value and turning the knob is used for configuration. Pressing again accepts the value.

Operating Control and Display Elements





RT100 Control System - front panel



Buttons

	Setting the set-point value		Scrolling through pages
	Setting the additional display		Setting the parameters
	Selection of the device functions (toggling SP1/SP2, drainage by suction, leak-stop)		Alarm reset and alarm history
	Button ON/OFF		











Status LEDs

	Normal operation		Warning		Alarm
---	------------------	---	---------	--	-------

Device Functions

	Set-point value toggling SP1/SP2		Draining (suction or blowing out)
	Leak-stop operation		

Symbols

	Interface operation		Level of the heat transfer medium (filled quantity) low
	Level of the heat transfer medium (filled quantity) OK		Heating
	Ramp program activated		Timer activated
	Cooling		Feed pump, counter clockwise rotation
	Feed pump, clockwise rotation		Alarm
	Maintenance due (flashes if maintenance is due)		

RT100 Control System - Displays

Operation and Status Displays



In the off state of the RT100 Control System, the message **OFF** appears in the display area. Upon switching on with the button **ON/OFF**, the additional display is shown. The top left part of the display shows the set-point temperature **SP1** or **SP2** (SP = Set point). The top right part of the display shows the current outlet temperature (actual value of temperature sensor **Sn1**, **Sn2** or **Sn3**).

Sn1 = Outlet temperature

Sn2 = Temperature, external

Sn3 = Inlet temperature



Three other selectable values are shown in the middle part of the display. The additional display can be set by using the F2 key and by turning/pressing the RCD control knob (turning selects a value, pressing confirms it).

The symbols for set-point value display, suction operation (draining) and leak-stop operation are shown in the lower left part of the display. The various operational and status displays of the temperature control unit are shown in the lower right part of the display.

Setting the Set-points



The set-point values **SP1** and **SP2** are set by pressing the key **F1**. The set-point value is then coloured light blue and can be set with the RCD control knob. This setting is also possible in the parameter positions. The set-point values can be selected through an external digital signal.



Toggling of the set-point values **SP1** and **SP2** is achieved with the **F3** key and selection of the set-point toggling function. Set-point toggling is only possible if there is no alarm pending.

Parameter Menu



The parameter menu is activated by pressing the Parameter button in this menu, all the parameters can be configured by turning/pressing the RCD control knob.

RT100 Control System - Functions

Powering Up



Upon switching on the main switch, **OFF** appears in the display. The RT100 Control System is now ready for operation and is switched on by pressing the **ON/OFF** button, or by the timer, through a digital input or an interface.

Depending on the programming, the set-point and actual values, as well as information on the operational state of the control system or the temperature control unit are displayed.

Rotational field detection / Direction reversal

The rotary field detection of the RT100 Control System detects a wrong phase sequence and reports this in the display or corrects the direction of rotation automatically.

Power Down



The RT100 Control System is switched off by pressing the **ON/OFF** button, or by the timer, through a digital input or an interface.

Depending on the temperature of the heat transfer medium, the switching off program runs as follows:

- The pump and the control system are turned off. The RT100 Control System is in standby mode and the display is **OFF**
- The pump continues to run. The device cools till the temperature of the heat transfer medium has reached the programmed run-on temperature then, the pump and the control system are turned off. In the case of devices using pressurised water, the pump runs for a few seconds in the opposite direction (pressure release). The RT100 Control System is in standby mode and the display is **OFF**

Leak-stop operation



The leak-stop operation is activated by pressing the **F3** key and selecting the leak-stop symbol and is only possible if it is supported by the device type.

The leak stop operation is only possible if water is used as the heat transfer medium and the set-point value is in the vicinity of the value run-on temperature (0-80 °C). Pressurised water units do not have any leak-stop operation.

When oil is used as a heat transfer medium, the set-point value must be within the range 0-250 °C. The heating capacity is then max. 60 %, since the thermal load of the oil must be kept low owing to the reduced pump capacity.

The leak-stop operation can be cancelled by pressing the **ON/OFF** button. When the **ON/OFF** button is pressed again (wait until the display reads **OFF**), the unit switches back to normal operation.

Clearance for the Leak-Stop Function

The leak-stop function is not permitted with every device (e.g. if a change in the direction of rotation of the delivery pump is not possible). The clearance of the leak-stop function is set in the parameter menu.



DANGER



The leak-stop operation is an emergency operation and may only be switched on or cleared for devices intended for the purpose. A leak-stop operation in the case of devices not intended for the purpose can cause a fire.

Draining

The consumer device can be drained with the delivery pump (suction) or with compressed air (blowing out); (setting in the parameter menu).

Drainage by Suction with Pump



The suction program allows the draining of the consumer connected at the temperature control unit and is activated by pressing the **F3** key and selecting the suction symbol. The pump is switched off and when the pump run-down time elapses, switched on again in the opposite direction. The consumer is drained through suction during the defined period (draining time).

Draining is only possible if the temperature of the heat transfer medium is below the programmed run-on temperature value. If that is not the case, the heat transfer medium is first cooled to this value.

Blowing out with Compressed Air

The blowing out program makes it possible to drain the consumer connected to the temperature control unit with compressed air. Blowing out is activated after the pump run-down time has elapsed and directs compressed air through the consumer. The temperature control unit switches off automatically after the set period (draining time) has elapsed.

The suction or blowing out program can be cancelled by pressing the **ON/OFF** button. When the **ON/OFF** button is pressed again (wait until the display reads **OFF**), the unit switches back to normal operation.

NOTE



In the case of pressurised water units, the pressure release valve closes 5 °C above the run-on temperature value (max. 85 °C) and opens at the programmed run-on temperature value during the cooling process.

Operation with Code/Password

In order to prevent the values that have been set or programmed from being set again unintentionally, the use of a code/password is earnestly recommended.

The RT100 Control System has three password levels that are organised hierarchically:

- User password - Default **0000** (switched off)
- Technician password - Default **0100**
- Service password - only for personnel trained by Regloplas

NOTE



It is earnestly recommended that an operator password should be set up when commissioning the temperature control device.

Operation with Timer

The RT100 Control System has an integrated real-time clock. If the option **Timer** is present, the device can be switched on and off with this option.

Alarm Reset and Alarm History

Alarm Reset



If an alarm has been triggered, the signal horn can be switched off by pressing the **Alarm Reset** button. After the malfunction has been rectified, the alarm can be reset by once again pressing the **Alarm Reset** button.

The **Alarm Reset** button also allows the manual acknowledgement of the automatic toggling from control of the consumer temperature **Sn2** to control of the outlet temperature **Sn1** in case of a faulty or removed sensor **Sn2** in the consumer.

Alarm History



If there is no alarm pending, the **Alarm Reset** button can be used to view the alarm history.

Save/Reset of the Setting Values

The RT100 Control System provides the facility to load the factory setting values or the user settings at any time in a simple manner. Two different customer-specific settings can be loaded afresh (user setting 1 and 2).

RT100 Control System - Loading firmware/bootloader

USB flash drive

- The empty USB flash drive must be formatted with FAT file system (see below)

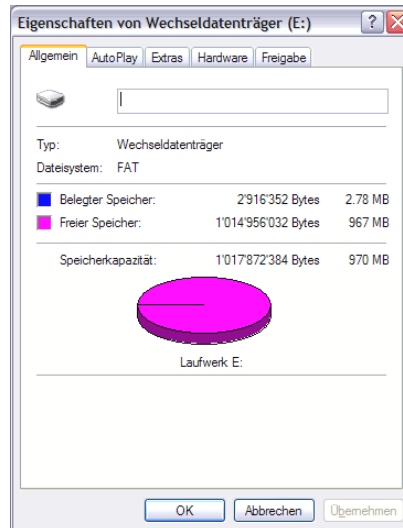

- The firmware must be extracted from the compressed file and copied to the USB flash drive (see below)

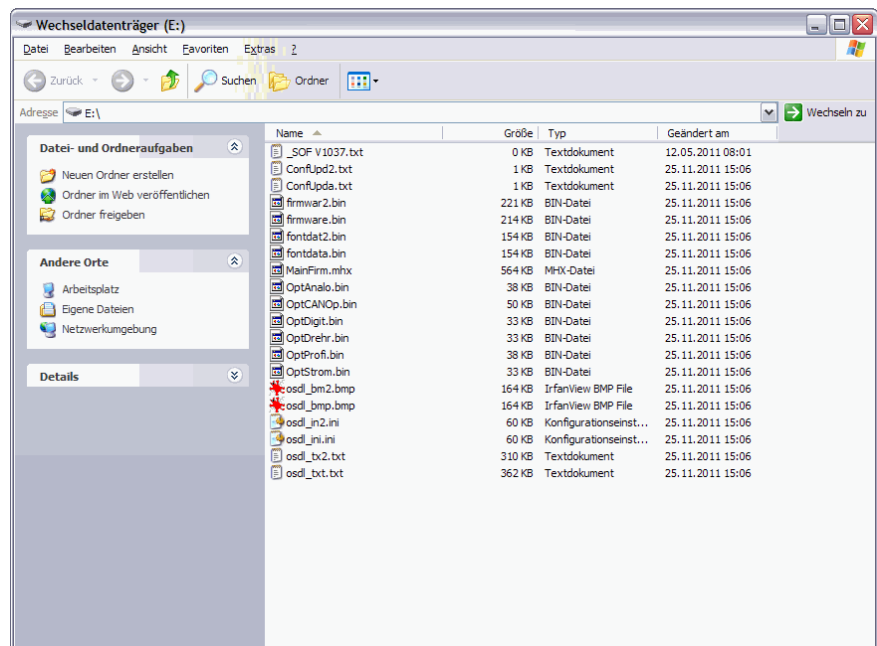

Loading the firmware/bootloader

CAUTION



The firmware must be loaded the first time that the device is switched on (main switch), otherwise, the parameter settings will be incorrect!



- Insert the USB flash drive containing the firmware into the USB port on the front panel
- Press and hold down front panel buttons **F1** and **F2** simultaneously
- Switch on the RT100 control system
- The RT100 control system will now load the bootloader
- As soon as the bootloader has loaded, the message **Update successful** will be displayed
- Press the panel button **F1**
- The RT100 control system will now load the new firmware
- Attention - during the loading process, the device may not be switched off under any circumstances!
- As soon as the firmware has loaded, the message **Update successful** will be displayed
- The device can now be started with button **F1** on the front panel
- The USB flash drive can be removed now

RT100 Control System - Activating Options

The RT100 control system can be equipped with different hardware and software options.

The software options must be activated with a file loaded by USB stick. This operation requires the serial number of the control system, which is displayed in the **Options** parameter and can be found on the base module next to the barcode. The serial number consists of 6 letters (e.g. AALASF).

- In the **Options** parameter, select the **Activate options** menu
- Now insert the USB stick with the options file (e.g. AALASF.opt - The options file can be on the same USB stick as the firmware)

Software options

- Universal interface
- Switch clock
- Ramp program
- Cascade inlet (sensor Sn3)
- Flow measuring F150
- Flow measuring F351
- Flow measuring F1000

- Reversal of rotation $>9A$ /suction
- Pump regulation
- Flushing
- Flow deviation
- Set-point ramps

Technical Data

RT100 Control System

General Data

RT100 Control System	
Temperature range	-25 - 450 °C
Control response	<p>Outlet control: PID-controller, with 10 hard-coded PID parameter sets or with a PID set that can be set manually. Separate parameter sets for heating and cooling</p> <p>Consumer control: PID-controller, with 10 hard-coded PID parameter sets or with a PID set that can be set manually</p>
Parameter input	Input via keyboard and RCD control knob
Data memory	Memory module with at least 10 years data retention time Timer with Lithium battery and about 10 years data retention time
Limit values	Adjustable maximum set-point value limit Programmable minimum and maximum deviation from the set-point value of the heat transfer medium temperature and consumer temperature
Monitoring equipment	<p>Continuous self-monitoring of the regulation and control system</p> <p>Probe breakage and sensor short-circuit (only in case of Pt100), probe breakage</p> <p>Limit values for temperature, pump current (all 3 phases), level, function of the heating and pump circuit breakers and the flow rate (option)</p> <p>Monitoring the plausibility of the data in the memory, the maintenance interval, the flow monitor, the calibration values, the phase sequence of the pump motor in compression or suction operation and of the external set-point value signal (option)</p>

Electrical Data

RT100 Control System	
Input supply voltage	Power supply (85-265 VAC)
Degree of protection	Front panel with membrane keyboard (IP54)
Maintenance	<p>Plug-in data memory, permanently connected to the temperature control device, for fast and simple changing of the base module without loss of data. The user data are automatically read into the new base module</p> <p>Integrated working-hour meter and maintenance interval display</p>

Inputs

RT100 Control System	
Temperature sensor	<p>Outlet: Pt100</p> <p>External (consumer): Optionally Pt100 (2- or 3-conductor), J (Fe-CuNi), K (NiCr-Ni), T (Cu-CuNi) or N (NiCrSi-NiSi) (Option), 20mA</p> <p>Inlet: Pt100 (2- or 3-conductor)</p>
External set-point value specification	Standardised and scalable, analog interface with 0/4-20 mA or 0-10 VDC
External heating-cooling command Device On/Off Program On/Off	Signal via potential-free contacts (option)
Set-point value toggling	Signal via keyboard (F3 key, standard) or via potential-free external contact (option)
Analog input	Electrically isolated analog set-point value input with scalable signal 0/4-20 mA or 0-10 VDC (option)

Outputs

RT100 Control System	
Heating/cooling	Triac outputs for circuit breakers or valves or solid-state relays (SSR)
Relay functions	<p>1 relay (standard), programmable as common alarm or as individual functions (e.g. temperature switching point, deviation etc.)</p> <p>3 relays (digital option), programmable as common alarm or as individual functions (e.g. temperature switching point, deviation etc.)</p>
Analog outputs	Electrically isolated analog outputs with scalable signal 0/4-20 mA or 0-10 VDC. An actual or set-point value can be assigned to every output. A thermal e.m.f. of a J-, K-, T- or N-element corresponding to the current display-actual can be output as the actual value output (option)

Data Interfaces (Option)

RT100 Control System	
Data transmission to control computer (hardware)	Various serial interfaces, Profibus DP, Euromap 66, Profinet-IO

Display

RT100 Control System	
Construction, design	Black LCD display with white lettering. Simultaneous display of actual and set-point values, three additional lines for important display values as well as one status line
Fault Indications	Are shown in the display unit

Precision

RT100 Control System	
Class accuracy / linearization	± 0.3 % of the display value, min. ± 0.5 °C Pt100: 0,3 % Thermocouples: 0,3 %
Deviation of the display	Pt100: ±1 digit Thermocouples: ±2 digits

Operation

RT100 Control System	
Operation	Operation using short-travel membrane key switch with pressure point in the membrane keyboard and RCD control knob (Regloplas Control Dial). Simple menu guidance in different languages. Set-point value and parameterisation protected through programmable codes

Dimensions

RT100 Control System	
Front dimensions	130 x 140 mm
Base module	170 x 230 mm

Parameterisation

General



The parameterisation of the RT100 Control System is carried out with the Parameter button in the menu **Parameters**. The corresponding parameter is selected and set by turning/pressing the RCD control knob.

The parameters are described in the following chapters.

CAUTION



The RT100 Control System has a safety concept with different password levels. Parameters with the password level "Service Engineer" may only be adjusted by personnel trained by Regloplas. Regloplas AG is not liable for damage that results from incorrect parameterisation!

Show actual values

(Password level - User password)

The respective current actual values are displayed in this menu:

Parameters	Remarks
Outlet temp.	Temperature of the heat transfer medium in the outlet - sensor Sn1 (in °C/°F)
External temp.	Temperature of the consumer in - sensor Sn1 (in °C/°F)
Inlet temp.	Temperature of the heat transfer medium in the inlet - sensor Sn3 (in °C/°F)
Heat./cool. power	Specification of the momentary output in % of the rated output (a negative value means cooling capacity in %)
Flow rate	Flow rate of the heat transfer medium in l/min or GPM
Pump pressure	Differential pressure across the pump
Pressure set-point	Pressure set-point value of the heat transfer medium (bar)
System pressure	Pressure of the heat transfer medium in the system (bar)
Outlet pressure	Pressure of the heat transfer medium in the outlet (bar)
Pump current L1	Current drawn by the pump motor - Phase 1 (in A)
Pump current L2	Current drawn by the pump motor - Phase 2 (in A)
Pump current L3	Current drawn by the pump motor - Phase 3 (in A)
Operating hours	Number of operating hours of the temperature control unit

Parameters	Remarks
Next service	Display of the remaining operating hours up to the next maintenance
Interface	Display of the interface (with code)
Address	Display of the device address in case of operation via interface
Date	Display of the current date
Time	Display of the current time
Num. level 1 low	Display of the number of level undershoots
Control cabinet temp.	Current temperature in the control cabinet (in °C/°F)
Software Version	Display of the implemented software version (front panel/base module)
Corr. set-point	Set-point value for auxiliary controller of the cascade control
Flow deviation	Deviation of the flow rate in l/min or GPM

Select language

(Password level - Technician password)

One of the languages currently available is selected in this menu (second line, German is in first line, English in second line).

The available languages are English, German, French, Italian, Spanish, Dutch, Czech, Chinese, Russian, Slovenian, Polish, Danish, Hungarian, Croatian, Romanian, Portuguese, Swedish and Japanese.

User settings

(Password level - Technician password)

Display

Parameter	Remarks
Contrast	Contrast of the display (in %)
Temperature display	Temperature display (in °C / 0.1 °C or °F)
Flow display	Flow display (in lpm or usGPM or ukGPM)
Pressure display	Pressure display (in bar or psi)
Zone display	Zone display (Manually or Auto)
Zone	Input of zone display if configuration is set on Manually

Clock

Parameter	Remarks
Time format	Selection of the time format (12/24-hour format)
Synchronize	Synchronisation of date and time

Switch clock

Parameter	Remarks
Clock programming (Software option)	Programming the clock (10 steps) There are 10 steps (connections) available for programming the clock. A day-of-the-week, a group of days of the week, a time and the type of time (On/Off time) must be programmed for every step. 2 steps are required so that the device is switched on once and off thereafter. The steps that are not required are set to inac-

Parameter	Remarks	
	tive. The active (On/Off) and inactive steps are visible in the second sub-level	
	Step 1-10	On/Off/Program 1-5 (Ramp program)/Inactive
		Monday, Tuesday, Wednesday, Thursday, Friday, Saturday, Sunday, Mo-Th, Mo-Fr, Mo-Sa, Mo-Su
		Time

Ramp program (Software option)

(Password level - Technician password)

Parameter	Range	Remarks		
Status	Program	Display the status of the current ramp program		
	Status			
	Loop			
	Step			
	Actual value			
	Set-point value			
	End set-point value			
	Remaining step time			
Program control	Program	Display ramp program		
	Status	Display status		
	START	Start ramp program		
	PAUSE	Pause ramp program		
	STOP + RESET	Stop/Reset Ramp program		
Program administration	Program 1	No. of steps	Program steps (2-20)	
		Start step	Starting steps (1-20)	
		Start trigger	Start takes place manually/clock	
		Stop behaviour	Switching off/last set-point value	
		No. of loops	Program passes (1-99)	
		Steps	Step 1	Set-point (in °C/°F)
	Ramp time (in hrs./min.)			
	Dwell time (in hrs./min.)			
	Start dwell time ("Directly" or when "Set-point reached")			
		Step 2	(Functions like Step 1)	
		Step 3	(Functions like Step 1)	
		Step 4	(Functions like Step 1)	
		Step 5	(Functions like Step 1)	
	Program 2	(Functions like Program 1)		
	Program 3	(Functions like Program 1)		
	Program 4	(Functions like Program 1)		
Program 5	(Functions like Program 1)			

Ramp program - Overview

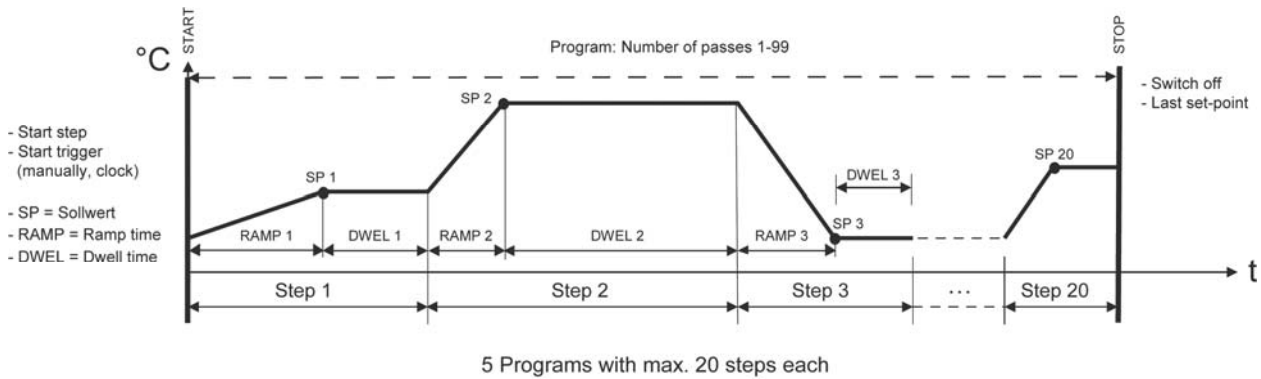

Set-point

Parameter	Range	Remarks	
Set-point at startup	Last set-point value	Upon switching on the temperature control unit, control takes place on the selected set-point value	
	Always SP1		
	Always SP2		
Set-point 1		Upon switching on, control is on the basis of the chosen set-point value temperature 1 (SP1)	
Set-point 2		Upon switching on, control is on the basis of the chosen set-point value temperature 2 (SP2)	
Set-point ramps (Software option)	Set-point ramp heating	Selection of the set-point ramp heating (Gradient, Filter or Inactive)	
		Gradient heating	Setting in °C/min
		Filter time constant heating	Setting in sec.
	Set-point ramp cooling	Selection of the set-point ramp heating (Gradient, Filter or Inactive)	
		Gradient cooling	Setting in °C/min
		Filter time constant cooling	Setting in sec.

Set-point ramps

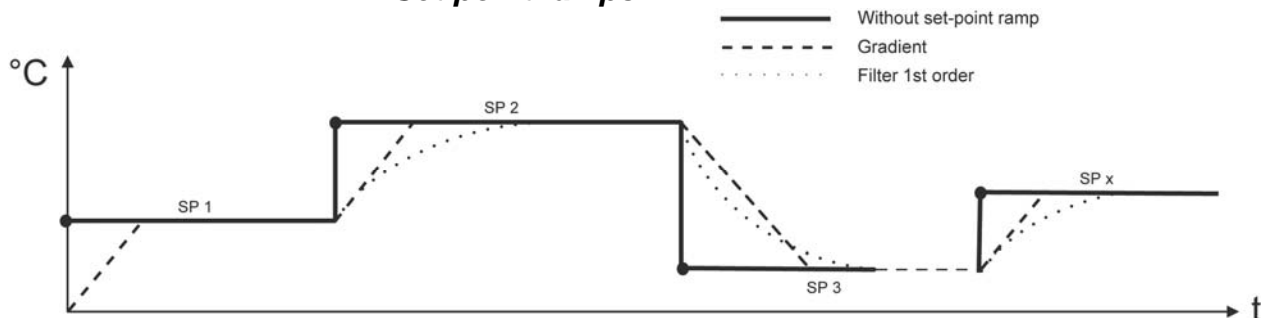

Evacuation time

Parameter	Remarks
Evacuation time	Evacuation time duration (0-500 sec.)

Next Service

Parameter	Remarks
Operating hours	Display of the operating hours
Next service	Setting the period up to the next maintenance (0 h = disabled)

Pump regulation

Parameter	Remarks
Pump pressure, Flow or Delta T set-point	Set-point setting (in bar, lpm or °C)
Operating mode	Operating mode setting (Manually or Auto)
Hand-value	Setting in Hz

USB Logging (Service Interface)

Parameter	Remarks	
Service Interface (USB Logging)	Data-Logging on USB-Stick	Active or Inactive

The USB Data logger is used for process-logging during production if no superordinate control is present.

If the USB logging is set on "active" and an USB flash drive is plugged in, every 10 seconds a record will be made. Per day (24 h) a file with the date in the file name and with the suffix "lo1" will be created (e.g. "20120825.lo1"). The records are provided with time and date.

In each case Set-point, Outlet temperature, External temperature, Inlet temperature, Heating-/Cooling performance, Flow rate, Pump pressure, System pressure and Pressure set-point will be stored. The csv file can for example be imported into Excel. There is also a special import filter for the Famos Reader software for quick overviews of data. Please use a Regloplas USB flash drive for USB logging (part no. 176-100026).

Monitoring

(Password level - Technician password)

Temperature deviation

Parameter	Remarks
Set-point value/outlet LO	Monitoring of this parameter can be switched on/off (value adjustable in °C/°F)
Set-point value/outlet HI	Monitoring of this parameter can be switched on/off (value adjustable in °C/°F)
Set-point value/external LO	Monitoring of this parameter can be switched on/off (value adjustable in °C/°F)
Set-point value/external HI	Monitoring of this parameter can be switched on/off (value adjustable in °C/°F)
Set-point value/Inlet LO	Monitoring of this parameter can be switched on/off (value adjustable in °C/°F)
Set-point value/Inlet HI	Monitoring of this parameter can be switched on/off (value adjustable in °C/°F)
Outlet/Inlet LO	Monitoring of this parameter can be switched on/off (value adjustable in °C/°F)
Outlet/Inlet HI	Monitoring of this parameter can be switched on/off (value adjustable in °C/°F)

Max. heat./cool. time

Parameter	Remarks
Max. heating time	Input ON/OFF
Deviation	Input in °C
Time	Input in minutes
Max. cooling time	Input ON/OFF
Deviation	Input in °C
Time	Input in minutes

Minimum flow rate

Parameter	Remarks
Minimum flow rate	Input - monitoring of the minimum flow rate (Active/Inactive)
Minimum flow rate	Setting the minimum flow rate (l/min or GPM)
Active from temperature	Minimum flow rate active from adjustable temperature (in °C/°F)

Flow deviation (Software option)

Parameter	Remarks
Flow deviation	Input - deviation of the minimum flow rate (Active/Inactive)
Low pass actual value	Actual value setting - low pass (in seconds)
Low pass offset reference	Offset setting - low pass (in seconds)
Deviation	Deviation setting (-100-0%)
Alarm suppression	Setting of duration of the alarm suppression (in sec.)

Flow monitoring

Two RT100 functions (Menu „Monitoring“)

- 1) Minimum flow rate
- 2) Flow deviation

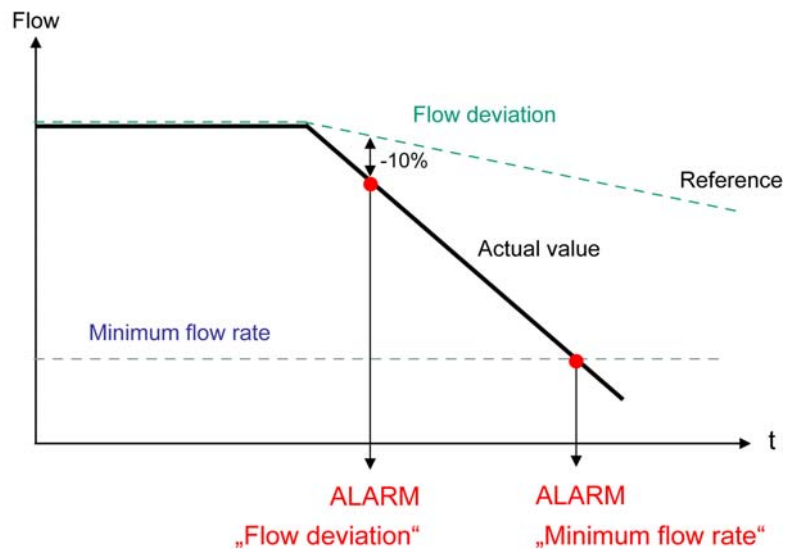

Min. system pressure

Parameter	Remarks
Min. system pressure	Input - min. system pressure (Active/Inactive)
Min. system pressure	Input - min. system pressure (in bar)
Alarm suppression	Setting of duration of the alarm suppression (in sec.)

Interfaces

(Password level - User password)

The universal interface is available as a software option.

Address

Parameter	Remarks
Address	Address input (0-999)
Protocol	Display of the current protocol with baud rate
Change protocol	Selection/setting of the available protocols (see chapter Data Interfaces)
Behaviour after comm. failure	Behaviour after communication failure (Input "Last status" or "Switch off")

Temperature control

(Password level - Technician password)

Temperature Regulation

Parameter	Remarks
Contr. type	Ext./outlet casc., Inlet/Outlet casc. or Outlet type
Outlet control par.	Control type with sensor in the outlet
Cascade external/outlet	Control type with sensor in the consumer and in the outlet
Cascade inlet/outlet	Control type with sensor in the inlet and in the outlet

Control parameters outlet

Parameter	Range	Remarks
Control parameter set	Fixed/manual	Selection of control parameter set
Control parameter outlet defined	Parameter set Heating	Selection of control parameter set Heating (1-10)
	Parameter set Cooling	Selection of control parameter set Cooling (1-10)
Control parameter outlet manual	P Heating	Setting control parameter P Heating (in °C/°F)
	I Heating	Setting control parameter I Heating (in sec.)
	D Heating	Setting control parameter D Heating (in sec.)
	Capacity limitation Heating	Capacity limitation Heating (0-100%)
	P Cooling	Setting control parameter P Cooling (in °C/°F)
	I Cooling	Setting control parameter I Cooling (in sec.)
	D Cooling	Setting control parameter D Cooling (in sec.)
	Power limit cooling	Capacity limitation Cooling (0-100%)
Neutral zone cooling	Setting of neutral zone cooling (0-10% of set-	

Parameter	Range	Remarks
		point value)

Control parameters cascade

Parameter	Range	Remarks
Control parameter set	Input fixed/manual	Selection of the control parameter set
Outlet limitation	Input active/inactive	Setting of outlet limitation
	Max. outlet limitation	Max. outlet limitation (in °C/°F, up to max. set-point value)
	Min. outlet limitation	Min. outlet limitation (in °C/°F)
Max. difference Int/Ext	Input active/inactive	Setting of outlet limitation
	Max. Diff. Heating Int/Ext	Max. Diff. Heating Int/Ext (in °C/°F)
	Max. Diff. Cooling Int/Ext	Max. Diff. Heating Int/Ext (in °C/°F)
Control parameter cascade defined	Value 1-10	Selection of control parameter Cascade fixed
Control parameter cascade manually	Strengthening of cascade	Input value 0-99
	Integral cascade	Input in sec.
	Differential cascade	Input in sec.
	P Heating auxiliary controller	Input in °C/°F
	I Heating auxiliary controller	Input in sec.
	D Heating auxiliary controller	Input in sec.
	P Cooling auxiliary controller	Input in °C/°F
	I Cooling auxiliary controller	Input in sec.
	D Cooling auxiliary controller	Input in sec.
Neutral zone aux. controller	Input in %	

Settings

Parameter	Remarks
Heating cycle time	Input of the pulse time heating (in seconds)
Min. heating control time	Input of the minimum actuation time heating (in milliseconds)
Cooling cycle time	Input of the pulse time cooling (in seconds)
Min. cooling control time	Input of the minimum actuation time, cooling (in milliseconds)

Control system modes

The RT100 Control System works with the following control algorithms:

- PID control on outlet, inlet or external sensor - for this control type, there are 10 fixed parameter sets each available for heating and cooling, as well as one manual set
- Cascade control with external sensor and outlet sensor as well as inlet sensor and outlet sensor

Fixed parameter sets

In order to save the operator the trouble of painstakingly defining the P, I, and D control parameters for heating and cooling, it is possible to retrieve fixed parameter sets adjusted to the applications.

Users can determine the best fixed set of parameters for their application without any special knowledge of control technology by observing the following simple rules:

1. Basic setting - parameter set 5
2. If the programmed set/point value is not attained after some time, then the next lower fixed parameter set (e.g. parameter set 4 instead of 5) should be selected
3. If the actual value exceeds the set-point value (overshooting) or varies about the set-point value, the next higher fixed parameter set is selected.

If none of these parameter sets lead to the desired stability of adjustment because the controlled system deviates from the standard, it is possible to create an individual parameter set.

Remark:

The set-point value is attained the fastest if the actual value overshoots somewhat. If overshooting is not permissible, then one must reckon with a somewhat longer heating-up time.

Pressure control

(Password level - Service password)

Parameter	Range	Remarks
Pressure Control	Input pressure control active/inactive	
Max. system pressure	Input max. system pressure (in bar)	
Set-point	Max. pressure set-point value	Input of the max. pressure (in bar)
	Min. pressure set-point value	Input of the minimum pressure (in bar)
	Set-point value, ramp	Input set-point value, ramp (in bar/second)
	Constant pressure overlay	Input constant pressure overlay (in bar)
	Percent pressure overlay	Input percent pressure overlay (in %)
Pressure balance	Pressure compensation type	Input pressure compensation with solenoid valve "Y2", "Y8.1" or "without"
	Pressure switch point	Input of pressure switching point (in bar)
	Pressure switching time	Input of pressure pulse time (in sec.)
Pressure increase	Pressure increase type	Input of pressure increase with solenoid valve "Y2", "Y2.1" or "Y2 always open"
	Pulse time	Input of pulse time (in sec.)
	Minimum actuation time	Input of the minimum actuation time (in milliseconds)
	P Band	Input P Band (in bar)
	Integral	Input integral (in sec.)
	Capacity increase at 1 bar	Input of capacity increase (in %)
	Capacity increase at 7 bar	Input of capacity increase (in %)
	Capacity limitation	Input of capacity limitation (in %)
Hysteresis over set-point value	Input of hysteresis (in bar)	
Pressure decrease	Cycle time	Input of pulse time (in sec.)
	Min. actuation time	Input of the minimum actuation time (in milliseconds)
	P band	Input P band (in bar)

Parameter	Range	Remarks
	Integral	Input integral (in sec.)
	Power increase	Input power increase (in %)
	Power limitation at 1 bar	Input limitation increase (in %)
	Power limitation at 7 bar	Input limitation increase (in %)
	Neutral zone	Input neutral zone (in bar)
	Min. system pressure	Input min. system pressure (in bar)
	Vapour suppression	Input of steam suppression (in sec.)

Pump regulation (Software option)

(Password level - Service password)

Parameter	Remarks
Control type	Input of the control type (Pump pressure, Flow rate or Delta T - Outlet/Inlet)
Operating mode	Input of operating mode (Manually or Auto)
Flow set-point	Input of set-point (in bar, lpm or °C)
Max. set-point	Input of set-point (in bar, lpm or °C)
Min. set-point	Input of set-point (in bar, lpm or °C)
Neutral zone	Input of neutral zone (in bar, lpm or °C)
Kp	Input of gain Kp
Reset time	Input of reset time (in sec.)
Derivative time	Input of derivative time (in sec.)
Max. output	Setting the output (in Hz)
Min. output	Setting the output (in Hz)
Hand-value	Input of hand-value (in Hz)

Unit configuration

(Password level - Service password)

Parameter	Remarks	
Device type	Selection of heat transfer medium (Water/Oil)	
Max. device temp.	Input of the maximum temperature of the temperature control unit (in °C/°F, normally 5-10 °C above the max. set-point value)	
Max. set-point	Input of the maximum set-point value of the heat transfer medium temperature (in °C/°F)	
Min. set-point	Input of the minimum set-point value of the heat transfer medium temperature (in °C/°F)	
Behaviour after power failure	Input behaviour after power failure ("Remains switched off", "Remains switched off - without error" or "Last status")	
Closing temperature	Input of closing temperature (in °C/°F)	
Pressure release	Pressure release type	Input pressure release type ("With pump", "With Y8/Y8.1" or "Without")
	Pressure release time	Input pressure release time (in sec.)
Switch off	Behaviour	Input "Cool first" or "Immediately off"
	Run-on temperature	Input run-on temperature when switching off

Parameter	Remarks		
	Run-on time	Input run-on time of pump after switching off	
	Cooling capacity	Input of cooling capacity for cooling process	
Emptying (Software option)	Evacuation type	Input evacuation type ("Inactive", "With pump" or "With pressure")	
		with pressure	with Y8/with Y18
	Venting time	Venting time duration (in sec.)	
	Evacuation time	Evacuation time duration (in sec.)	
Leak stop	Allow leak stop	Input allow leak stop (yes/no)	
Pump	Nominal current, pump	Input nominal current pump (in A)	
	Monitor phase sequence	Input monitor phase sequence (yes/no)	
	Run-down time of pump	Input run-down time of pump (in sec.)	
	Automatic reversal of direction of rotation >9A	Input automatic reversal of direction of rotation >9A (yes/no)	
Boost pump	Monitoring	Input active/inactive	
	Maximum running time	Input in (in sec.)	
	Restart lockout	Input in (in sec.)	
	Active from set pressure	Input in (bar)	
Heating	Output Heating	Input 'heating output' ("SSR AC", "SSR DC", "SSR DC aux. cont." or "Contactor")	
	Heating 2	Input heating 2 (active/inactive)	
Cooling	Cooling principle	Input cooling type ("Direct", "Indirect" or "Indirect/direct")	
	Temperature switchpoint indirect/direct	Input of switching point (in °C/°F)	
	Cooling medium conveying	Input of cooling medium conveying ("With SK-pump", "Without SK-pump" or "With 3-way valve")	
	Antiblocking SK-pump	Active/Inactive if cooling medium conveying is set "With SK-pump" (Activation of SK-pump every 30 min. for 100 milliseconds)	
	Cooling valve reset time	Input of reset time, cooling valve (in sec.)	
Level	Refilling after	Input refilling after ("Power on" or "Control on")	
	Run-on time, pump	Input run-on time of pump (in sec.)	
	Refilling time window	Input of refilling time window (in sec.)	
	Level counter	Input active/inactive	
	Number of level undershoots	Input possible number of level undershoots	
	Alarm suppression time	Input of alarm suppression time (in minutes)	
	Number of fluid reservoir	Number of heat transfer medium container	
	Monitoring Y2	Input Active/Inactive	
	Max. turn on time Y2	Input turn on time (in sec.)	
	Response delay	Input (in sec.)	
Min. refill time	Input (in sec.)		
Flushing	Flushing	Input flushing time ("Off", "With Y19" or "With Y2/Y8")	
	Settings	Start flushing	(Active/Inactive)
		Start flushing time	(in sec.)

Parameter	Remarks		
		Max. flushing temperature	(in °C)
		Interval flushing	(Active/Inactive)
		Interval time	(in min.)
		Interval flushing time	(in sec.)

Inputs

(Password level - Technician password)

The parameters of the signal inputs are displayed in this menu.

Parameter	Range	Remarks	
Temperature sensor Sn1	Offset	Input of offset (in °C/°F)	
Temperature sensor Sn2	Offset	Input of offset (in °C/°F)	
	Sensor type Sn2	Input of sensor type Sn2 ("No ext. Sensor", "Pt100 2-conductor", "Pt100 3-conductor", "TE Type K", "TE Type J", "TE Type T", "TE Type N" or "4-20 mA", "Interface")	
Temperature sensor Sn3 (Software option)	Offset	Input of offset (in °C/°F)	
	Sensor type Sn2	Input of sensor type Sn2 ("No ext. Sensor", "Pt100 2-conductor" or "Pt100 3-conductor")	
Pressure sensor 1, system	Pressure sensor 1	Input pressure sensor 1 (active/inactive)	
	Offset	Input of offset (in bar)	
	4 mA	Input 4 mA (in bar)	
	20 mA	Input 20 mA (in bar)	
Pressure sensor 2, outlet	Pressure sensor 2	Input pressure sensor 2 (active/inactive)	
	Offset	Input of offset (in bar)	
	4 mA	Input 4 mA (in bar)	
	20 mA	Input 20 mA (in bar)	
Flow rate (Software option)	Flow meter	Input flow meter (Inactive/Basemodule/Option)	
	Flow meter type	Input flow meter type ("F150", "F160", "F181", "F183", "F185", "F350", "F351", "scalable", "F1000")	
	Additional parameters in case of flow meter type "Scalable"	Input (X26-KEM, X27-F150)	
		Scaling 1 kHz (in lpm or GPM)	
		Filtering time constant (in sec.)	
Additional parameters in case of flow meter type "F1000"	(see the chapter "Flow meter type F1000")		
Flow monitor	Input "Inactive/Pressure switch/Pump pressure"		
	When selecting "Pump pressure"	Min. pump pressure (in bar)	
	Alarm suppression time	Input in (in sec.)	
Temp. monitor cooling	Input "Active/Inactive"		
Analog input	Analog input	Input "Pump current" or "Set-point"	
	Analog input	Input "0-10 V", "0-20 mA", "4-20 mA" or "Inactive"	
Ext Start/Stop command	Code 0	When the external contact closes, the unit is	

Parameter	Range	Remarks
(digital or analog option)		turned off and the ON/OFF button is blocked
	Code 1	When the external contact opens, the unit is turned off and the ON/OFF button is blocked
	Code 2	The unit can be switched on and off via the external contact (closing of the external contact - unit switches off / opening of the external contact - device switches on)
	Code 3	The unit can be switched on and off via the external contact (closing of the external contact - unit switches on / opening of the external contact - device switches off)
	Code 4	The unit can be switched on and off as follows (closing of the external contact - unit switches on / opening of the external contact - unit switches off, the ON/OFF buttons, leak stop and discharge as well as start/stop by serial interface are inactive)
	Code 5	The unit will be switched off immediately by closing of the external contact - Warning Device external switched off immediately will be shown. The unit can not be switched on until the contact will be opened. There will be no cooling or pressure relief, so the device may still be very hot and under pressure!
	Code 6	The unit will be switched off immediately by opening of the external contact - Warning Device external switched off immediately will be shown. The unit can not be switched on until the contact will be closed. There will be no cooling or pressure relief, so the device may still be very hot and under pressure!
	For code 2 and 3, the following applies: Switching on and off with the button ON/OFF is possible at any time	
Differential pressure filter (digital or analog option)	Input "Opening/Closing"	

Flow meter type F1000 (Software option, max. 300 lpm)

Parameters	Remarks
Flow meter	Active/inactive
Flow meter type	F1000
Pump type	Display of the pump type
Settings	(see the following chapter "Settings")

Settings

Parameters	Remarks
Pump tolerance	Deviation in % of the expected max. pump pressure. If this value is not reached, an error message will be shown ("Pump power too low")
Pump calibration value	Correction value of the pump calibration (can also be input manually)
Pump pressure	ON - Differential pressure outlet/system OFF - only outlet pressure

Parameters	Remarks
Filtering time constant	Averaging time of the flow
Automatic calibration	Switching automatic pump calibration on or off
Manual calibration	Start manual calibration
Pump pressure	Display of the pump pressure during calibration

Manual calibration

Manual calibration starts when, in the menu, the parameter **Manual calibration** is set to **ON**. The user is thereupon prompted to close the ball valve in the outlet (flow = 0 l/min). When the ball valve is closed, the parameter **Manual calibration** is set to **OFF** and then the ball valve is opened again. Calibration is now complete.

The parameter **Manual calibration** only appears in the menu when Automatic calibration is set to **OFF**.

Automatic calibration

If the parameter **Automatic calibration** is set to **ON**, then every time the pump starts, the time-controlled automatic pump calibration will be executed (there must be a solenoid valve present in the outlet for this purpose). The following parameters can be defined for the automatic calibration:

Parameters	Remarks
Time till calibration	Time till switching on the solenoid valve in seconds
Calibration time	Switching time of the solenoid valve in seconds
Time till re-calibration	Time till repetition of the calibration in seconds. With 0 seconds, the calibration is not repeated

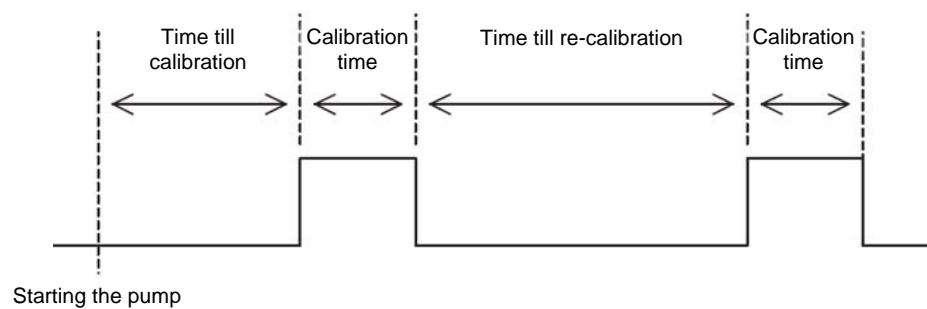

Importing the characteristic curve

The characteristic curve must be saved in the csv format and is divided into a header area and a data area. The existing characteristic curve can be overwritten by a new characteristic curve at any time. In the menu item **Save/Load / Load characteristic curve F1000**, a characteristic curve can be loaded from the USB stick.

Outputs

(Password level - Technician password)

The parameters of the signal outputs are displayed in this menu.

Parameter	Range	Remarks	
24 VDC outputs	O1	Continuously inactive	
		Continuously active	
		Alarm	Common alarm (see the parameter "Common alarm")
			Heating 1
			Heating 2
			Minimum flow rate
			Flow monitor
			Level
			Pump current
			Deviation Set-point value/Outlet HI
			Deviation Set-point value/Outlet LO
			Deviation Set-point/External HI
			Deviation Set-point/External LO
			Deviation Set-point/Inlet HI
			Deviation Set-point/Inlet LO
			Deviation Outlet/Inlet HI
		Deviation Outlet/Inlet LO	
		Deviation Flow rate	
		Temp. switching point (in °C/°F)	
		Flow switching point (in lpm or GPM)	
		Band deviation (in °C/°F)	
		Control on	
		Clock active	
		Pump is running	
		Level 1 reached	
		Level 2 reached	
	Heating 1 on		
	Heating 2 on		
	Cooling on		
	Pressure increase		
	Pressure decrease		
	Maintenance		
	Pump regulation Start/Stop		
	O2	Data input output O2 (for functions, see output O1)	
		Pump regulation Right/Left	
	O3	Data input: output O3 (for functions, see output O1)	

Parameter	Range	Remarks
Analog output 1 (analog option)	Analog output 1	Inactive, 4-20 mA, 0-20 mA, 10 V, TE Type J, TE Type N, TE Type T, TE Type K
	Layout	Outlet temperature, External temperature, Inlet temperature, Set-point value 1, Set-point value 2, Flow rate, Set-point, Pump regulation
	Lower end of scale	in corresponding dimension unit
	Upper end of scale	in corresponding dimension unit
	Offset	in corresponding dimension unit
Analog output 2 (analog option)	Analog output 2	Inactive, 4-20 mA, 0-20 mA, 10 V, TE Type J, TE Type N, TE Type T, TE Type K
	Layout	Outlet temperature, External temperature, Inlet temperature, Set-point value 1, Set-point value 2, Flow rate, Set-point, Heat./cool. power
	Lower end of scale	in corresponding dimension unit
	Upper end of scale	in corresponding dimension unit
	Offset	in corresponding dimension unit

Relay

(Password level - Technician password)

The parameters of the relay functions are displayed in this menu:

Parameter	Range	Remarks	
Relay K1	Function	Input "Opening/Closing/Single shot lead. edge"	
	Relay	Control unit ON	
		Clock activated	
		Pump running	
		Level 1 reached	
		Level 2 reached	
		Heating 1 ON	
		Heating 2 ON	
		Cooling ON	
		Pressure increase	
		Pressure decrease	
		Service	
		Max heat./cool. time	
	Power ON		
	Alarm	Common alarm (see the parameter " Common alarm")	
		Heating 1	
		Heating 2	
Minimum flow rate			
Flow monitor			
Level			
Pump current			

Parameter	Range	Remarks
		Deviation Set-point/Outlet HI
		Deviation Set-point/Outlet LO
		Deviation Set-point/External HI
		Deviation Set-point/External LO
		Deviation Set-point/Inlet HI
		Deviation Set-point/Inlet LO
		Deviation Outlet/Inlet HI
		Deviation Outlet/Inlet LO
		Deviation Flow rate
		Temp. switch point (actual value in °C/°F)
		Flow switch point (in lpm or GPM)
		Band deviation (actual value in °C/°F)
		Pump switch ON
Relay K2 (digital option)	Function	Input "Normally open/Normally closed"
	Relay	(for functions, see Relay K1)
Relay K3 (digital option)	Function	Input "Normally open/Normally closed"
	Relay	(for functions, see Relay K1)
Relay K4 (digital option)	Function	Input "Normally open/Normally closed"
	Relay	(for functions, see Relay K1)

Collective alarm

(Password level - Technician password)

The common alarm is configured in this menu. The common alarm can be assigned to a relay or to a 24 VDC output.

Parameter	Remarks
Alarm repeat time	Input alarm repeat time (in sec.)
Heating 1	Input alarm heating 1 (On/Off)
Heating 2	Input alarm heating 2 (On/Off)
Min. flow rate	Input alarm min. flow rate (On/Off)
Flow deviation	Input alarm deviation of flow rate (On/Off)
Flow monitor	Input alarm flow monitor (On/Off)
Level	Input alarm level (On/Off)
Pump current	Input alarm pump current (On/Off)
Temp. monitor cooling	Input alarm cooling temperature monitor (On/Off)
Current monitor heating	Input alarm Current monitor heating (On/Off)
SSR DC aux. contact	Input SSR DC aux. contact (On/Off)

from SOF V1102:

In the case of the following alarms, the common alarm relay is always activated:

- Switch over heat carrier - reboot of the machine required
- RTC Error or empty battery - time and date settings lost
- External set-point signal disconnected or not available

- Direction of rotation cannot be changed
- Software version incompatible:
Analog Option, Digital Option, Heating current monitoring, Reversal of direction of rotation, Profibus, Profinet, Ethernet/IP, CAN Demag, CANopen
- Option missing or faulty:
Analog Option, Digital Option, Heating current monitoring, Reversal of direction of rotation, Profibus, Profinet, Ethernet/IP, CAN Demag, CANopen
- AD converter failure
- Attention - temperature control cabinet too high
- Turn on time refill exceeded
- Maximal operating time boost pump exceeded
- Min. pump pressure underrun
- Max. temperature exceeded Sn3
- Max. temperature exceeded Sn2
- Max. temperature exceeded
- Heating thermostat is activated
- Frequency converter alarm
- Motor current underrun
- Phase sequence failure
- Phase sequence unidentified
- Phase missing
- Motor contactor malfunction
- Temperature sensor Sn1 failure
- Temperature sensor Sn2 failure - switched to outlet control
- Temperature sensor Sn3 failure
- System pressure sensor inactive
- System pressure sensor failure
- Power failure
- Safety thermostat is activated
- Deviation set-point value/outlet exceeded
Deviation set-point value/outlet underrun
Deviation set-point value/external exceeded
Deviation set-point value/external underrun
Deviation set-point value/inlet exceeded
Deviation set-point value/inlet underrun
Deviation outlet/inlet underrun
Deviation outlet/inlet underrun

Save/Load

Parameter	Remarks
Load user setting 1	Loading the user settings 1
Save user setting 1	Saving the user settings 1
Load AIC factory settings	Loading the user settings AIC
Save AIC factory settings	Saving the user settings AIC
Loading the factory settings	Loading the factory settings
Save the factory settings	Saving the factory settings (Regloplas password required)
Load settings from USB stick	Loading the settings from the USB stick
Save settings to USB stick	Saving the settings to the USB stick
Load characteristic curve F1000	Loading the characteristic curve F1000 (pump characteristic) from the USB stick

Code

The password parameters are displayed in this menu:

Parameter	Range	Remarks
User password	New password	Input new password
	Repeat	Repetition of password input
	Set	Activation of the password
Technician password	New password	Input new password
	Repeat	Repetition of password input
	Set	Activation of the password
Service password	New password	Input new password
	Repeat	Repetition of password input
	Set	Activation of the password
Reset passwords	Reset code (if the password has been forgotten, a corresponding reset code is required)	Input of the reset code (four-digit)
	Reset	Resetting to default passwords (ex-factory)

Options

The RT100 Control System options are displayed in this menu.

The RT100 Control System offers a releasing facility of software and hardware options for function enhancement. The software options are released through a USB stick.

Parameter	Range	Remarks
Hardware options	Analog option	Installed hardware options are displayed. To remove an option, it should be manually set to OFF
	Digital option	
	Option current monit. heating	
	Option reversal of rotation	
	Option Profibus	
	Option CANOpen	
	Option CAN Demag	
	Option Profinet	
	Option Ethernet/IP	
	Option Flow	
Software options	Universal interface	Activated software options are displayed. For releasing a software option, a code is required (file on USB stick). The serial number of the control system is required for this purpose
	Switch clock	
	Ramp program	
	Cascade inlet	
	Flow rate measurement F150	
	Flow rate measurement F351	
	Flow rate measurement F1000	
	Reversal of direction of rotation/suction	
	Pump regulation	
	Flushing	
	Flow deviation	
	Set-point ramps	
	USB Logging	
Activate options	Wait for USB stick	Detection of the USB stick, load software options from the USB stick. The serial number of the control system is required for this purpose
Serial number	Display of the base module serial number of the RT100 Control System (8 letters, e.g. AALARP)	

Current monitoring heating

(Password level - Technician password)

Parameter	Range	Remarks	
Current monitoring	Input active/inactive		
	Settings	Current converter ratio	
		Max. current Heating 1 (in A)	
		Min. current Heating 1 (in A)	
		Max. current Heating 2 (in A)	
		Min. current Heating 2 (in A)	
	Heating current L1	(display in A)	
	Heating current L2	(display in A)	
Heating current L3	(display in A)		

Service menu

(Password level - Service password)

Parameter	Range	Remarks
Software versions	Software version	Display of the current software version
	Compatibility	Display of the current software version, the corresponding options and the system
	Analog option	
	Digital option	
	Current monitoring option	
	Option reversal of direction of rotation	
	Compatibility	
	Option Profibus	
	Option CANOpen	
	Option CAN Demag	
	Option Profinet	
Delete alarm list	Input of the Regloplas-AIC password required	
IO Test	Output	"None", "X40-M1", "X41-Y2", "X42-Y8", "X43-Y16, Y13", "X45-Y19", "X46-M2", "X47-Y6" or "X48-Y8.1"
		"Active", "Inactive"
	Output	"None", "X40-M1", "X41-Y2", "X42-Y8", "X43-Y16, Y13", "X45-Y19", "X46-M2", "X47-Y6" or "X48-Y8.1"
		"Active", "Inactive"

Multiflow

See therefore the corresponding Multiflow User manual.

Data Interfaces

Basic Concept

The operation with data interfaces makes possible an external, superordinate control system of the temperature control unit. The choice of the protocol and the address of the data interface is described in the **Parameterisation** chapter.

Protocols

	Designation	Baud rate	Interface	Address
	Inactive			
1	Aarburg	4800 Bd	20 mA-CL	
2	Engel CL	4800 Bd	20 mA-CL	
5	Stork	1200 Bd	20 mA-CL	
6	Ferromatik Milacron	4800 Bd	20 mA-CL	
7	Klöckner Desma	4800 Bd	20 mA-CL	
8	Demag Ergotech	4800 Bd	20 mA-CL	
9	Krauss Maffei	4800 Bd	20 mA-CL	
10	Dr. Boy	4800 Bd	RS 232	
15	Sächsische Kunststofftechnik	4800 Bd	RS 485	
16	CAN Demag Ergocontrol	615 kBd		A13-17
18	Engel RS232	4800 Bd	RS 232	
19	SPI	19.2 kBd	RS 485	A32-255
20	SPI	9600 Bd	RS 485	A32-255
21	SPI	4800 Bd	RS 485	A32-255
22	SPI	2400 Bd	RS 485	A32-255
23	SPI	1200 Bd	RS 485	A32-255
24	Bühler Dataspeed	4800 Bd	RS 485	
25	Frech Datacontrol	9600 Bd		A11-18
26	Frech Datacontrol	4800 Bd		A11-18
27	Frech Datacontrol	2400 Bd		A11-18
28	Frech Datacontrol	1200 Bd		A11-18
29	CAN Demag Ergocontrol	500 kBd		A13-17
30	CAN Demag Ergocontrol	250 kBd		A13-17

	Designation	Baud rate	Interface	Address
31	CAN Demag Ergocontrol	125 kBd		A13-17
33	Profibus DP	max. 12 MBd	RS 485	A0-124
34	Ferromatik Milacron RS485	4800 Bd	RS 485	
35	Bühler Dataspeed	9600 Bd	RS 485	
36	Ethernet/IP		Ethernet	IP Address
37	Profibus DP (Alarm Reset)	max. 12 MBd	RS 485	A0-124
38	Euromap 66	250 kBit/s	CANOpen (Euromap 66)	Netstal from 31
39	Profibus DP (Pump regulation)	max. 12 MBd	RS 485	A0-124
40	Profibus DP (Protocol V2)	max. 12 MBd	RS 485	A0-124
41	Profinet IO	100 MBd	Profinet IO	
42	Profinet IO	100 MBd	Profinet IO	
43	Engel	4800 Bd	RS 485	
44	Ethernet/IP	100 MBd	Ethernet	IP Address
45	Regloplas	19.2 kBd	RS 485	A0-124

Plug Nomenclature

RT100 Front panel

Plug		Designation
X2		Options
X3		Base module
X4		Interfaces Universal RP or 20 mA CL
X5		USB Host
X6		USB Device

RT100 Base Module

Plug		Designation
X1		Display and operations module (front panel)
X2		Base module
X3		Options
X4		Options
X5		Options
X6		Power supply
X7		EEPROM (Memory)
X10:1		Flow monitor F3/B42
X10:2		Flow monitor F3/B42
X11:1		Level switch S3
X11:2		Level switch S3
X12:1		Level switch S1
X12:2		Level switch S1
X13:1		Digi In (Feedback frequency converter)
X13:2		Digi In (Feedback frequency converter)
X14:1		Digi In (Monitoring SK pump)
X14:2		Digi In (Monitoring SK pump)
X15:1		Sensor, internal (Pt100) B1
X15:2		Sensor, internal (Pt100) B1
X16:1		Sensor, external (Pt100 / TC+) B3

Plug		Designation
X16:2		Sensor, external (Pt100 / TC-) B3
X16:3		Sensor, external (Pt100) B3
X17:1		Sensor, inlet (Pt100) B14
X17:2		Sensor, inlet (Pt100) B14
X17:3		Sensor, inlet (Pt100) B14
X18:1		Sensor, external (4-20mA) B3
X18:2		Sensor, external (4-20mA) B3
X20:1		Digi In
X20:2		Digi In
X21:1	+	Heating 1 24VDC
X21:2	-	Heating 1 24VDC
X22:1	+	Heating 2 24VDC
X22:2	-	Heating 2 24VDC
X23:1	+	Digi Out (Frequency converter Start/Stop)
X23:2	-	Digi Out (Frequency converter Start/Stop)
X24:1	+	Digi Out (Frequency converter Right/Left)
X24:2	-	Digi Out (Frequency converter Right/Left)
X25:1	+	Digi Out
X25:2	-	Digi Out
X26:1		COM flow rate measurement F18x, F35x
X26:2		Signal flow rate measurement F18x, F35x
X26:3		Shield flow rate measurement F18x, F35x
X27:1		BN flow rate measurement F150
X27:2		GN flow rate measurement F150
X27:3		WH flow rate measurement F150
X28:1	+	Pressure sensor 1, system B8
X28:2	-	Pressure sensor 1, system B8
X29:1	+	Pressure sensor 2, outlet B8.1
X29:2	-	Pressure sensor 2, outlet B8.1
X30:1		Relay K1 NO
X30:2		Relay K1 COM
X30:3		Relay K1 NC
X31:1	L	Feedback Delivery
X31:2		Feedback Delivery
X32:1	L	Feedback Heating 1
X32:2		Feedback Heating 1
X33:1	L	Feedback Heating 2
X33:2		Feedback Heating 2
X34:1	L	Thermostat F7
X34:2		Thermostat F7
X35:1	L	AC In
X35:2		AC In
X36:1	L	AC In
X36:2		AC In
X37:1	L	AC In

Plug		Designation
X37:2		AC In
X38:1	COM	Safety thermostat F5
X38:2	NO	Safety thermostat F5
X38:3	NC	Safety thermostat F5
X40:1	N	Cooling pump SK M1 / Compressed air Y16.1
X40:2	L	Cooling pump SK M1 / Compressed air Y16.1
X40:3	PE	Cooling pump SK M1 / Compressed air Y16.1
X41:1	N	Valve refill Y2 / Additional lower level lamp H3
X41:2	L	Valve refill Y2 / Additional lower level lamp H3
X41:3	PE	Valve refill Y2
X42:1	N	Valve pressure release Y8
X42:2	L	Valve pressure release Y8
X42:3	PE	Valve pressure release Y8
X43:1	N	Compressed air Y16 / Air inlet Y13
X43:2	L	Compressed air Y16 / Air inlet Y13
X43:3	PE	Compressed air Y16 / Air inlet Y13
X44:1	N	Delivery, Heating 1+2
X44:2	L	Heating 1 K21-23
X44:3	L	Heating 2 K24-26
X44:4	L	Delivery, K10
X45:1	N	Valve flushing Y19 / Blow out OFF Y18
X45:2	L	Valve flushing Y19 / Blow out OFF Y18
X45:3	PE	Valve flushing Y19 / Blow out OFF Y18
X46:1	N	Filling pump M2
X46:2	L	Filling pump M2
X46:3	PE	Filling pump M2
X47:1	N	Valve, Cooling Y6
X47:2	L	Valve, Cooling Y6
X47:3	PE	Valve, Cooling Y6
X48:1	N	Valve Additional pressure release Y8.1
X48:2	L	Valve Additional pressure release Y8.1
X48:3	PE	Valve Additional pressure release Y8.1
X49:1	L	Valve Outlet (Flow rate F1000 NO)
X49:2	L	AC Out
X49:3	L	AC Out
X50:1	T1	Delivery pump M10
X50:2	T2	Delivery pump M10
X50:3	T3	Delivery pump M10
X50:4	PE	Delivery pump M10
X51:1	L1	Mains input 200-600V
X51:2	L2	Mains input 200-600V
X51:3	L3	Mains input 200-600V
X51:4	L	Mains input 115/230V
X51:5	N	Mains input 115/230V
X51:6	PE	Mains input

RT100 Digital Option

The digital functions of the RT100 Digital Option are mirrored identically on the RT100 Analog Option.

Digital Functions

Plug	Designation
X80:1	External heating
X80:2	External cooling
X80:3	External heating/cooling active
X80:4	External On/Off
X80:5	External toggling SP1-SP2
X80:6	Differential pressure, filter
X80:7	External Start program
X80:8	External Stop program
X80:9	GND X80: 1-8

Relay Functions

Plug	Designation
X81:1	Relay K2 NO
X81:2	Relay K2 COM
X81:3	Relay K2 NC
X81:4	Relay K3 NO
X81:5	Relay K3 COM
X81:6	Relay K3 NC
X81:7	Relay K4 NO
X81:8	Relay K4 COM
X81:9	Relay K4 NC

RT100 Analog Option

Digital Functions

Plug	Designation
X100:1	External heating
X100:2	External cooling
X100:3	External heating/cooling active
X100:4	External On/Off
X100:5	External toggling SP1-SP2
X100:6	Differential pressure, filter
X100:7	External Start program
X100:8	External Stop program
X100:9	GND X100: 1-8

Analog Functions

Plug	Designation
X101:1	Analog input set-point value
X101:2	+ 15 VDC
X101:3	Analog output 1 V
X101:4	Analog output 1 mA
X101:5	Analog output 1 TC
X101:6	Analog output 2 V
X101:7	Analog output 2 mA
X101:8	Analog output 2 TC
X101:9	GND outputs X101: 1, 3-8

RT100 Option Reversal of Direction of Rotation >9A

The RT100 option for reversal of the direction of rotation >9A is intended for motor currents >9 A.

Plug	Designation
X120:1	Pump motor T1
X120:2	Pump motor T2
X120:3	Pump motor T3
X120:4	Pump motor PE
X121:1	Mains supply L1
X121:2	Mains supply L2
X121:3	Mains supply L3
X121:4	Mains supply PE

RT100 Option Current Monitoring Heating

Plug	Designation
X150:1	Current converter 1
X150:2	Current converter 1
X150:3	Current converter 2
X150:4	Current converter 2

RT100 Option Multiflow (connection)



Plug	Designation
X200:1	External Input 24 VDC
X200:2	External Input GND
X200:3	Shield, Ground
X200:4	Internal Output 24 VDC
X200:5	External Output 24 VDC
X200:6	GND Internal/External Output
X200:7	CAN High
X200:8	CAN Low
X200:9	Address

Hardware

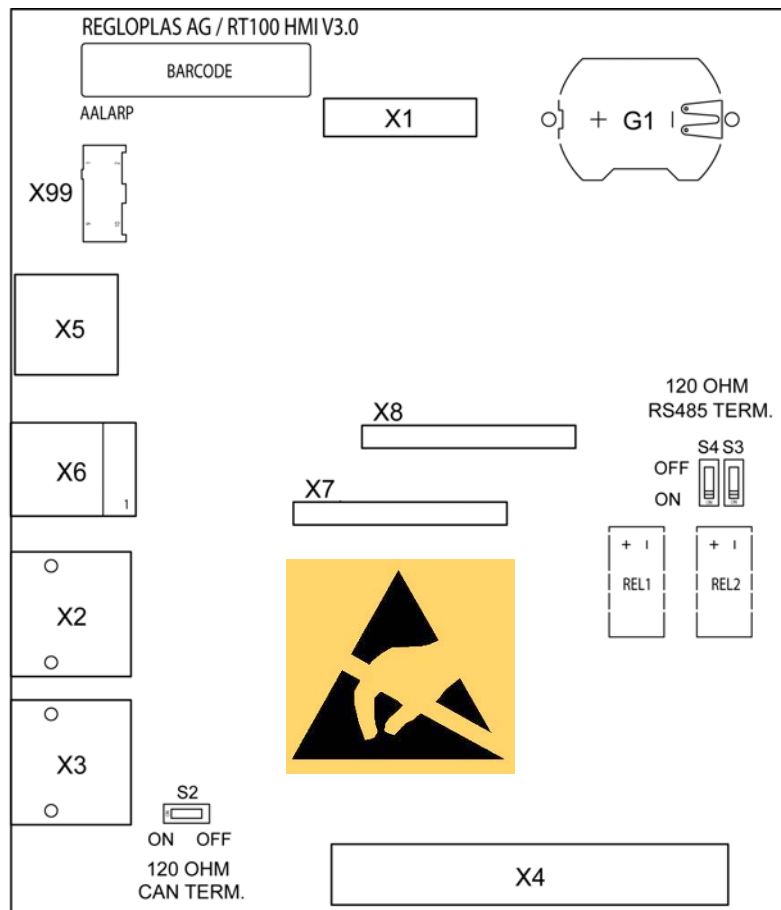
RT100 Front Panel - Layout



RT100 Front Panel Print - Layout

 CAUTION	
	<p>Electronic parts can be damaged by electrostatic charges. For this reason, proper grounding must be ensured during installation!</p> <p>Fasten an antistatic wristband to your wrist before installing electronic components!</p>

RT100 Base Module - Layout

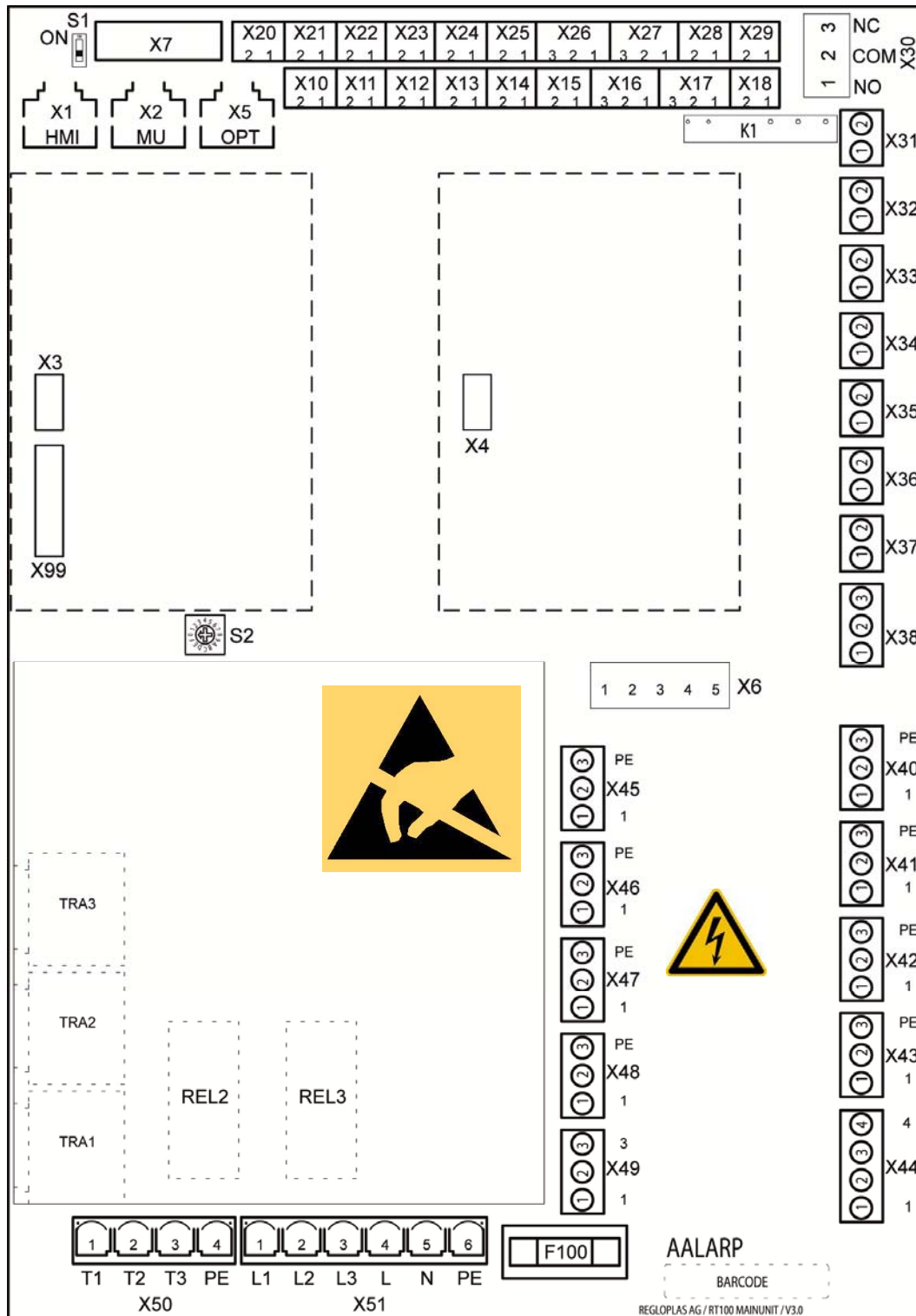

RT100 Base Module - Layout

Analog Option - Layout

The digital functions of the RT100 Analog Option are mirrored identically on the RT100 Digital Option.

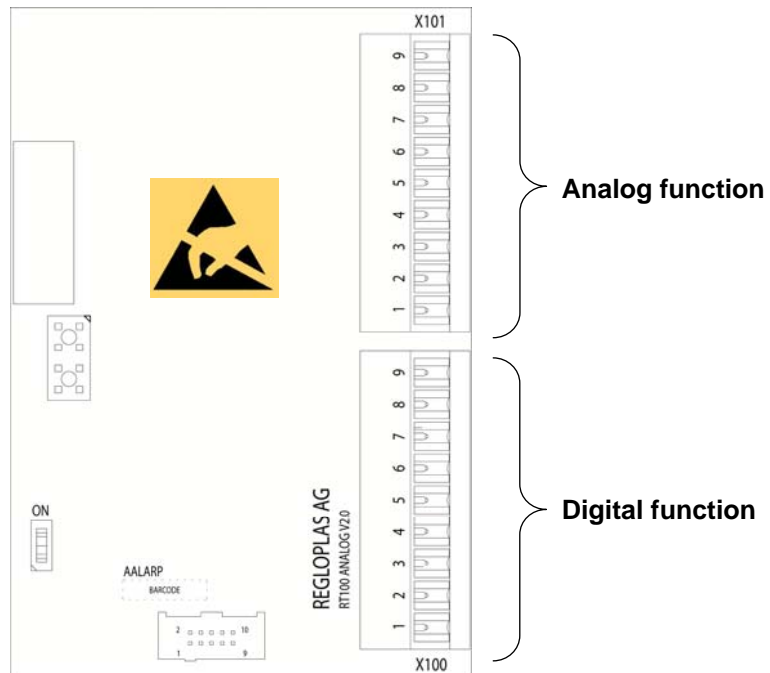

Analog Option - Layout

CAUTION



If both a digital option and an analog option are installed, the digital functions of the digital option must be used!



The digital functions of the analog option are not activated in this case!

Digital Option - Layout

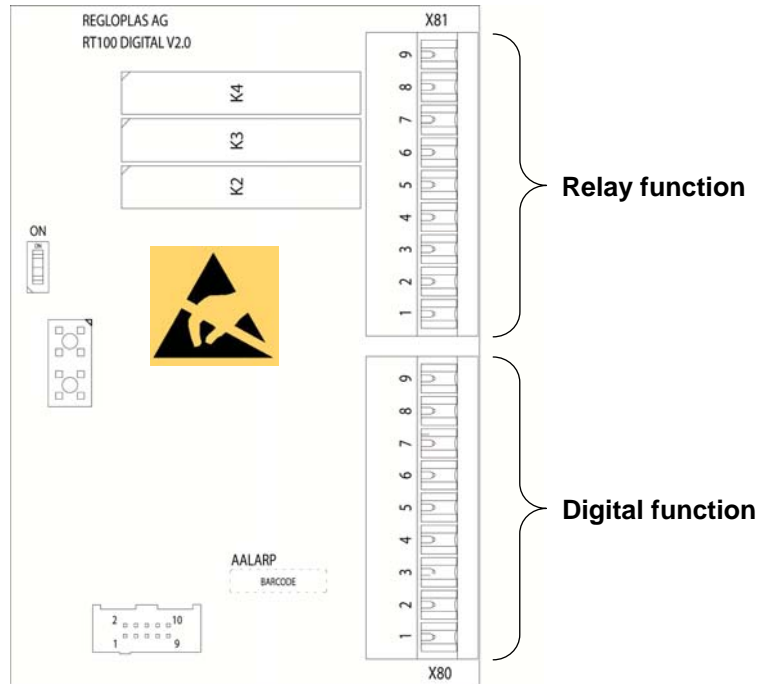
The digital functions of the RT100 Digital Option are mirrored identically on the RT100 Analog Option.



Digital Option - Layout

 CAUTION	
	<p>If both a digital option and an analog option are installed, the digital functions of the digital option must be used!</p> <p>The digital functions of the analog option are not activated in this case!</p>

Option Reversal of Direction of Rotation >9A - Layout

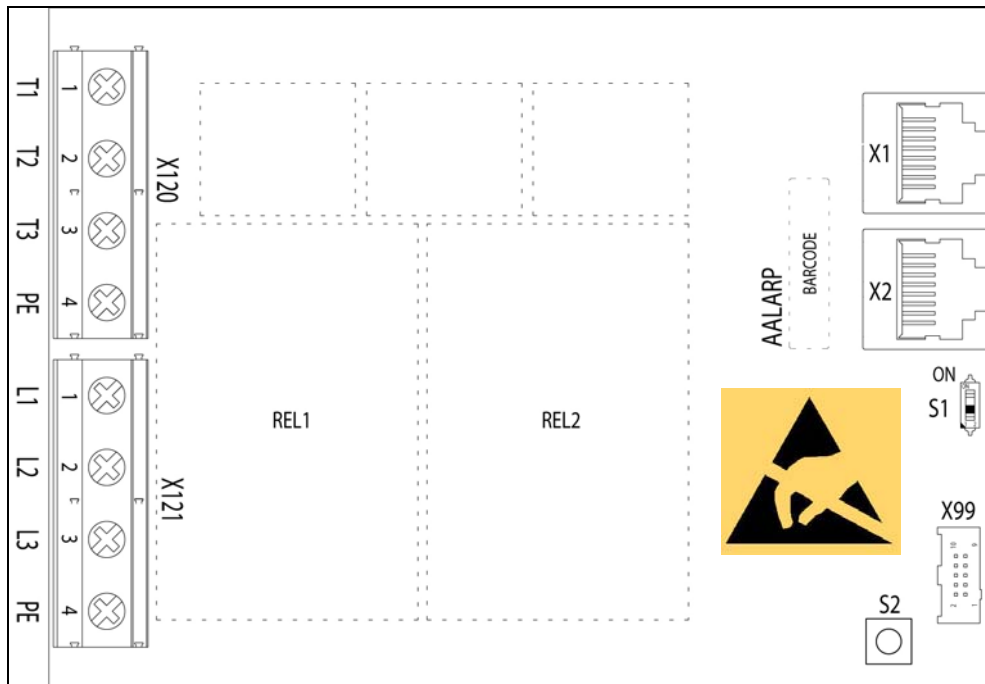

Option Reversal of Direction of Rotation >9A - Layout

Option Current Monitoring Heating - Layout

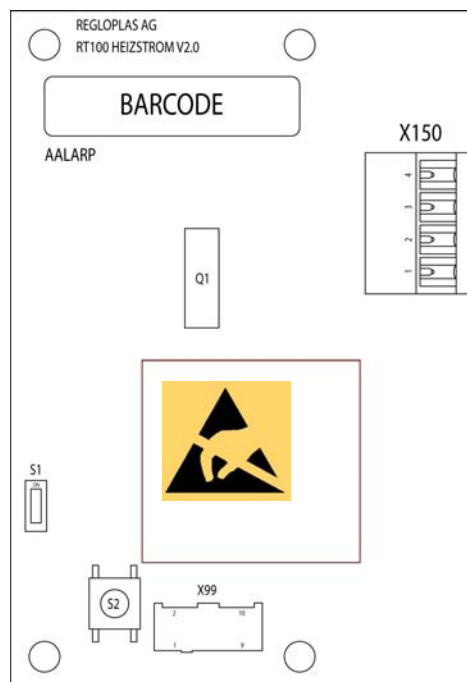

Option Current Monitoring Heating - Layout

Option Profibus DP - Layout

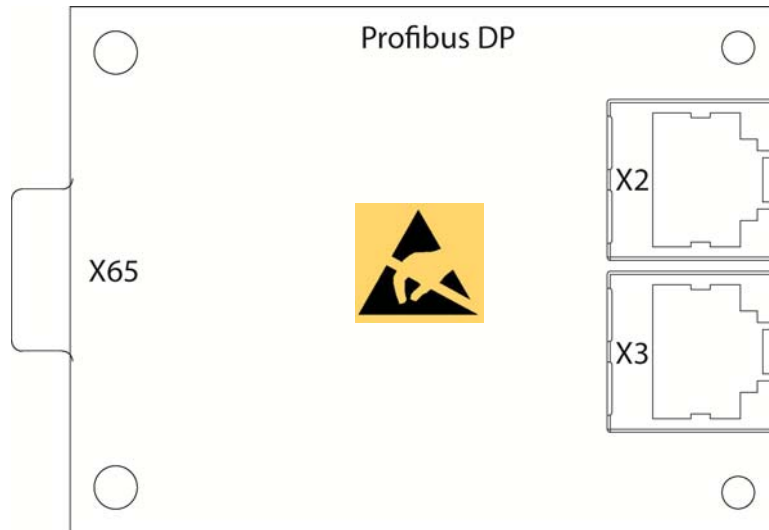

Option Profibus DP - Layout

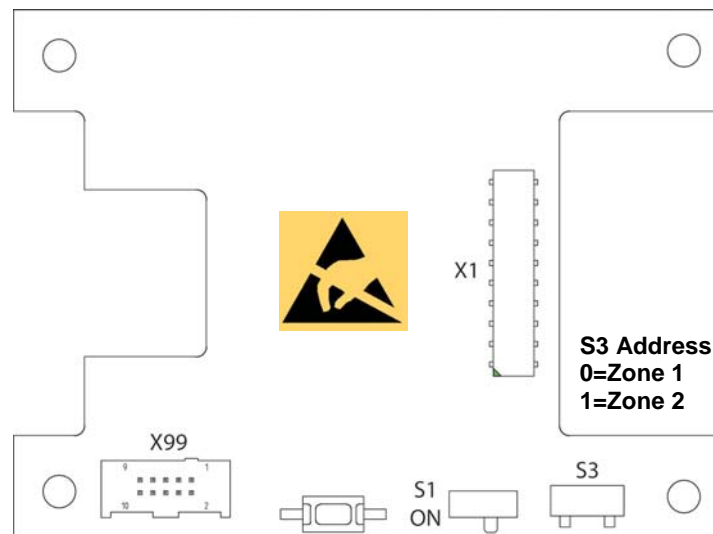

Board for Mainboard-Options - Layout

Option Euromap 66 - Layout

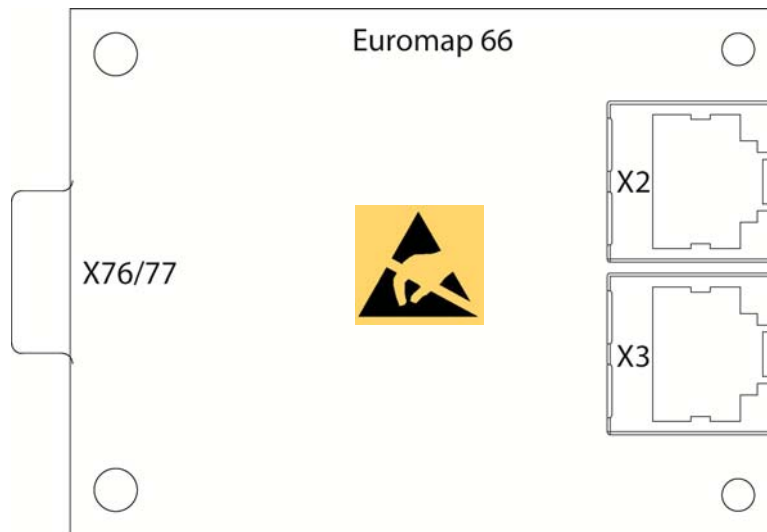

Option Euromap 66 - Layout

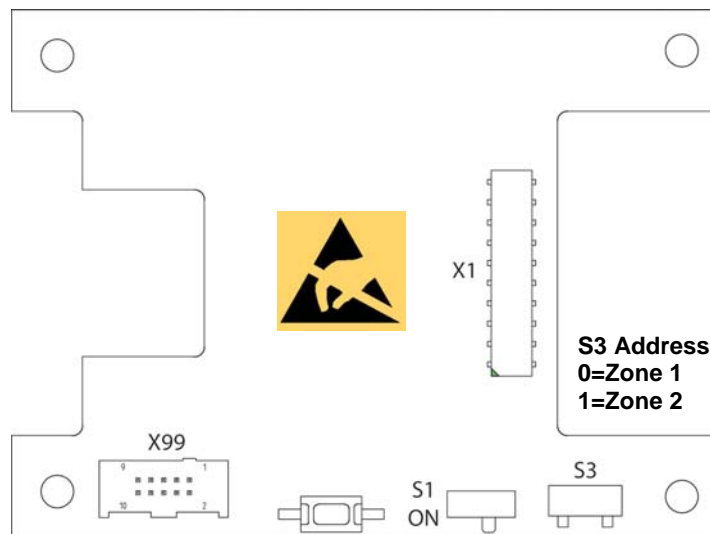

Board for Mainboard-Options - Layout

Option Profinet-IO - Layout

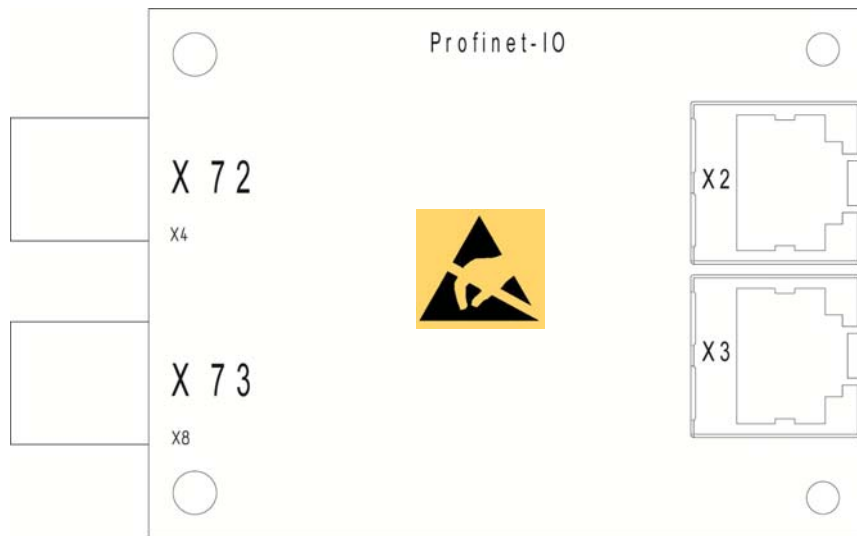

Option Profinet-IO - Layout

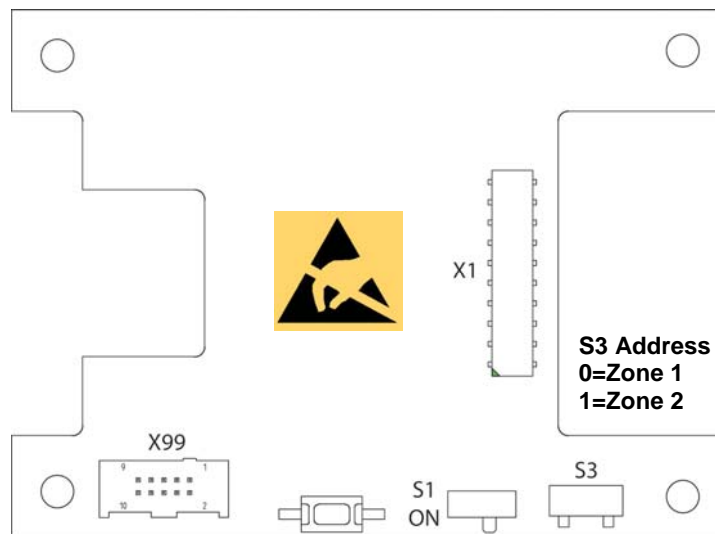

Board for Mainboard-Options - Layout

Option Multiflow - Layout

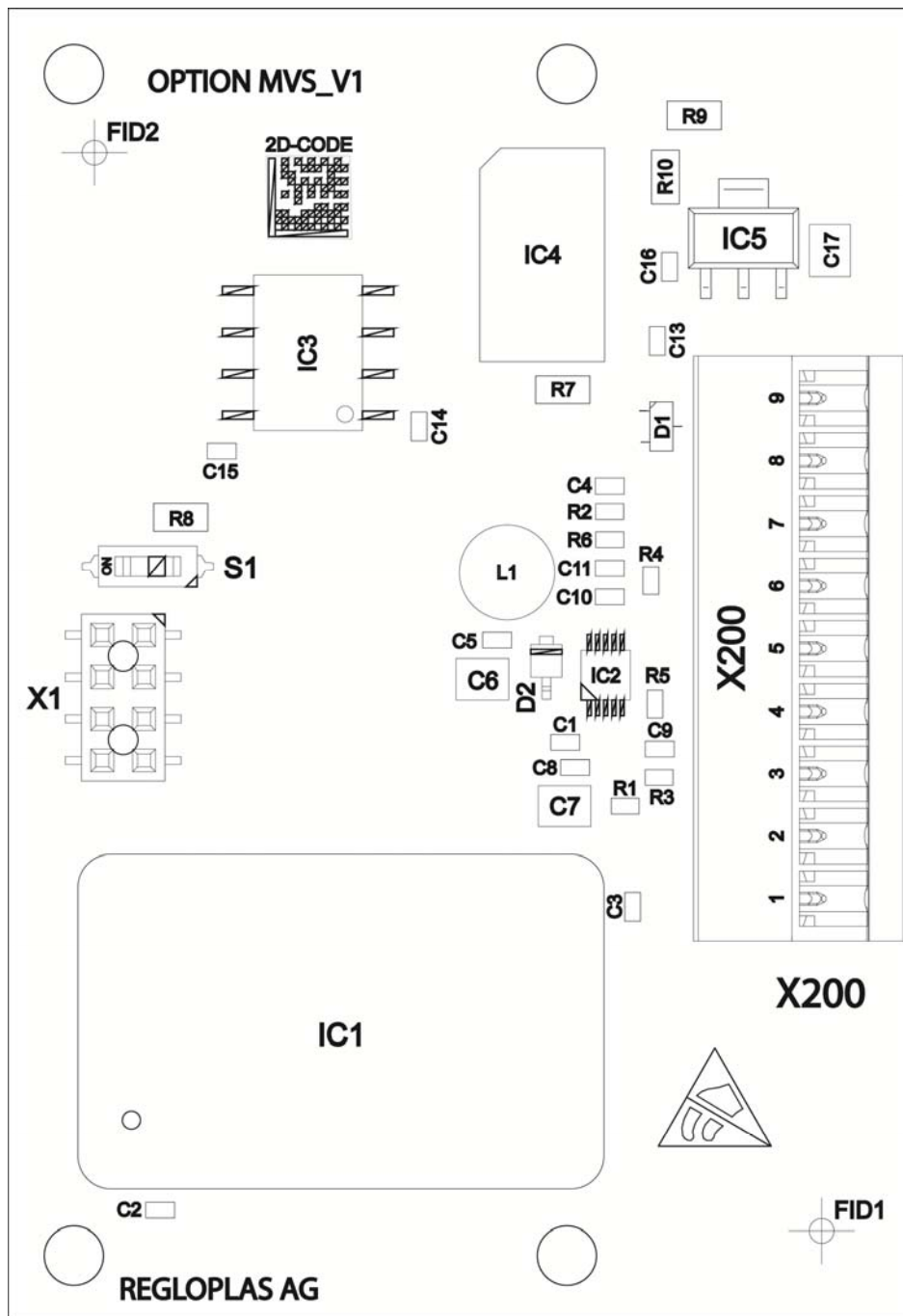

Option Multiflow - Layout

Fault Rectification

Alarm Messages



The RT100 Control System can display various error messages (warnings and alarms). Attention must be paid to these error messages without fail, otherwise, malfunctions of / damage to the temperature control unit and production downtimes may result.

Pressing the **Alarm Reset** button allows you to acknowledge/reset an alarm (e.g. switching off the horn). Only after the malfunction has been rectified can the alarm display be deleted by once again pressing the **Alarm Reset** button.

The **Alarm Reset** button also allows the manual acknowledgement of the automatic toggling from control of the consumer temperature (or cascade control) **Sn2** to control of the outlet temperature **Sn1** in case of a faulty or removed sensor **Sn2** in the consumer.

Alarm List



Pressing the **Alarm Reset** button opens the alarm list as long as there is no alarm queued. The last ten alarm messages with date and time are displayed here.

Warnings

Error message	Rectification
Service is due	Carry out maintenance procedure according to the operating manual. Increment the parameter Next Maintenance by 1000 hours
Clean filter	Clean the corresponding filter or if required, replace it
Current data lost, load factory settings	The RT100 Control System has lost the parameters and had to load the factory settings
Outlet pressure sensor faulty	Replace outlet pressure sensor
Heating contactor 1 failure	The contactor Heating 1 does not get actuated correctly any more - replace
Heating contactor 2 failure	The contactor Heating 2 does not get actuated correctly any more - replace
Illegal or broken characteristic curve F1000	Switch the main switch off and on again. If the fault is still present, re-load characteristic curve F1000
Pump power too low	Check/inspect the pump or in the menu F1000 reduce the parameter pump tolerance (default 50%)

Error message	Rectification
Deviation set-point value/outlet underrun	Adjust the outlet temperature and acknowledge the fault
Deviation set-point value/outlet exceeded	Adjust the outlet temperature and acknowledge the fault
Deviation set-point value/external underrun	Adjust the external temperature and acknowledge the fault or error
Deviation set-point value/external exceeded	Adjust the external temperature and acknowledge the fault or error
Deviation set-point value/inlet underrun	Adjust the inlet temperature and acknowledge the fault
Deviation set-point value/inlet exceeded	Adjust the inlet temperature and acknowledge the fault
Deviation outlet/inlet underrun	Adjust the inlet temperature and acknowledge the fault
Deviation outlet/inlet exceeded	Adjust the inlet temperature and acknowledge the fault
Level 2 underrun	Refill heat transfer medium
Pressure balance not possible	Check water inflow pipe and water pressure (min. 2 bar)
Leak stop not possible	Reduce the temperature
Leak stop not allowed	Unit is not allowed for leak stop
Suction not possible	Switch the unit to normal operation mode
SSR error	SSR DC with auxiliary contact has activated. Check SSR

Alarms

Error message	Rectification
External set-point signal disconnected or not available	Connect the external set-point value signal (optionally check control system)
Maximal operating time boost pump exceeded	Check hose connections to the consumer, fix the leakages
Flow monitor is activated	Check outlet pressure (min. 0,7 bar must be available)
Min. pump pressure underrun	Check outlet pressure
Min. flow rate underrun	Check min. flow rate (the specified min. flow rate must be available)
Flow rate deviation too high	Large variation in the flow (there may be a leak in the circuit)
Max. temperature exceeded Max. temperature Sn2 exceeded Max. temperature Sn3 exceeded	Max. heat transfer medium temperature may not exceed the die max. device temperature (optionally check the consumer temperature)
Heating thermostat is activated	Temperature control unit has become too hot - let it cool down and determine the cause
Heating current monitoring is activated	Check heating element(s) and replace, if necessary
Direction of rotation cannot be changed	---
Motor current underrun	Check pump/pump motor (with ohmmeter) and replace, if necessary
Motor current exceeded	Check pump/pump motor (with ohmmeter) and replace, if necessary
Phase sequence failure	Correct the phase sequence (interchange 2 phases)
Phase sequence unidentified	Switch off phase sequence monitoring

Error message	Rectification
Phase missing	Check the mains, input conductor and pump motor
Motor contactor malfunction	Check motor contactor and if required, replace it
Temperature sensor Sn1 failure	Replace temperature sensor Sn1
Temperature sensor Sn2 failure - switched to outlet control	Replace temperature sensor Sn2
Temperature sensor Sn3 failure	Replace temperature sensor Sn3
System pressure sensor failure	Replace the system pressure sensor
System pressure sensor inactive	Activate the system pressure sensor
Power failure	Failure of the power supply or temperature control unit not switched off properly
Safety thermostat is activated	Temperature control unit has become too hot - determine the cause and reset the thermostat
Temp. monitor cooling act, cooling disabled	Check the cooling and cooling water flow
Frequency converter alarm	Remedy the frequency converter fault
Turn on time refill exceeded	Check the cooling water circuit and the cooling circuit for leaks
Level 1 underrun	Refill heat transfer medium

System Errors/System Notes



Error message	Rectification
Memory stick missing	Insert memory stick
AD converter failure	Replace the base module
Attention - temperature control cabinet too high	Place the temperature control unit in a place with low ambient temperature
Incompatible data on stick	Load current software version
Communication failure	Check the connection between the front panel and the base module
Software version error	Re-load software (applies to front panel and base module)
Data corrupt on stick	Insert new memory stick and re-load device parameters
Current settings lost / factory settings loaded	Carry out a new client-specific settings parameterise
Settings defect / data not loaded	Replace the memory stick
No data on USB stick or wrong file extension	Load the correct data on USB stick
More than 1 file on USB stick	Load the correct data on USB stick
Data failure - no data loaded from USB stick	Load the correct data on USB stick
Option not activated	Activate the option
DEMO MODE / Pump current measurement inactive	System message without remedial action
Saving data	Data saving in progress
Data saved	Data saving finished
Data error - no data saved to USB stick	Replace the USB stick
Pump is off or has wrong direction	Adjust the pump rotating field
Please close tap	Close the tap on the outlet
Calibration done - please open tap	Open the tap on the outlet
Clean the filter	Clean the external filter
External set-point signal disconnected or not available	Connect the external set-point signal
RTC Error or empty battery - Time and date settings	Set the correct date/time and/or replace the battery on

Error message	Rectification
lost	the front panel
USB Slave mode operation not possible	Switch on the temperature control unit again
Save/Load not possible in USB Slave Mode	Switch on the temperature control unit again
Save/Load not possible during device is on	Switch the temperature control unit to OFF
Switch over heat carrier - reboot of the machine required	Switch on the temperature control unit again with the main switch
Error, password not reset	Enter the reset code correctly
Password reset	Password was reset
Illegal operation	Observe the operating sequence
Zone 1 missing	Connect Zone 1, check address of Zone 1
Zone 2 missing	Connect Zone 2, check address of Zone 2
Software version option incompatible: Analog Option, Digital Option, Heating current monitoring, Reversal of direction of rotation, Profibus, Profinet, Ethernet/IP, CAN Demag, CANopen	Update the software
Option missing or faulty: Analog Option, Digital Option, Heating current monitoring, Reversal of direction of rotation, Profibus, Profinet, Ethernet/IP, CAN Demag, CANopen	Connect the corresponding option or switch off in the parameter Hardware Options

RT100 Control System - Maintenance/repair

Replacing the front panel

Removal

 CAUTION	
	<p>The exact sequence of operations described below must be strictly followed. Otherwise, parameterization errors are possible!</p> <p>The address of the base module must be correct before the control system is powered up for the first time. Otherwise, the base module boot loader will have to be reloaded by the manufacturer!</p>

- Disconnect all plug-in connections
- The front panel is fixed with 6 screws on the device door. Loosen all the screws and remove the defective front panel
- Send the defective front panel to Regloplas AG (Switzerland) in ESD protective packaging, complete with a description of the fault

Installation

- Fasten the front panel with 6 screws on the device door
- Reconnect all plug-in connectors

Loading the firmware

See the section "RT100 Control System - Loading the firmware".

Replacing the base module

Removal

 **CAUTION**

The exact sequence of operations described below must be strictly followed. Otherwise, parameterization errors are possible!

The address of the base module must be correct before the control system is powered up for the first time. Otherwise, the base module boot loader will have to be reloaded by the manufacturer!

- Disconnect all plug-in connections
- Carefully unplug the memory card
- The base card is fixed inside the device with 6 screws. Loosen all the screws in alternation so that the plastic spacer bolts do not fall out
- Send the defective base module card to Regloplas AG (Switzerland) in ESD protective packaging, complete with a description of the fault

Installation

- Fasten the base card inside the device with 6 screws. Tighten the screws in alternation to avoid twisting the base card
- Reconnect all plug-in connectors
- Carefully reinsert the memory card

Hardware checklist

- Is the CAN connecting cable correctly plugged in?
- Are the CAN terminating resistors set to the correct **ON/OFF** position?
- Are the addresses of the base module (main units) correctly set? (zone 1 = address 0, zone 2 = address 1 - very important for dual devices with a single display)
- Is the motor fuse F10 (10 A aM/Class CC) fitted?
- Is the relay plug K1 connected?

Loading the firmware

See the section "RT100 Control System - Loading the firmware".

Activating options

See the section "RT100 Control System - Activating options".

Loading the factory settings

The factory settings are restored in the **Save/Load** parameter in the **Load factory settings** menu. This returns the RT100 to the manufacturer's default settings.

Configuration check

The unit configuration must be checked to determine whether everything has functioned correctly. Important points to check in the **Unit configuration** parameter:

- Unit type (oil, water)
- Maximum temperature in device
- Emptying - Evacuation type
- Pump - Nominal pump current in the Unit configuration parameter
- Pump - Automatic reversal of direction of rotation

Customer-specific settings

The corresponding customer-specific parameter settings must be re-entered (e.g. interface addresses etc.)

CAN terminating resistors and address settings

On delivery of the assembly, the CAN terminating resistors on the base module (switch **S1**) and on the front panel (switch **S2**) are set to **ON**.

On delivery, the address of the base module is **0** (rotary switch **S2**).
In the case of dual units, address **1** is set for zone 2 (rotary switch **S2**).

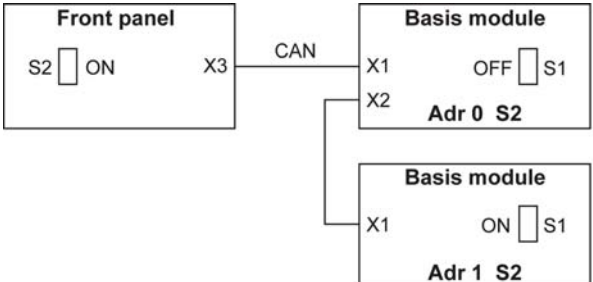
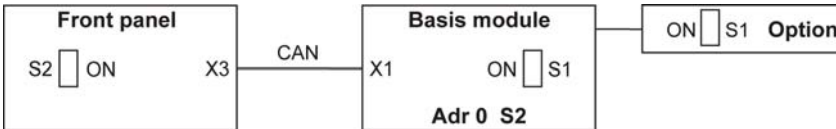
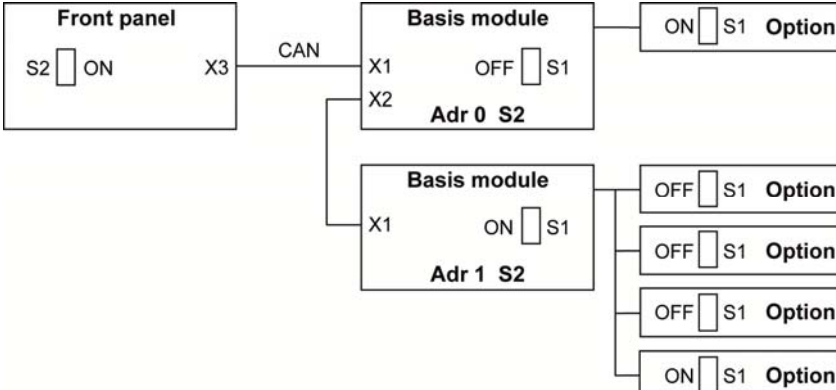
No.	Connection combination	Description
1	Front panel with one base module	 <p>Both terminating resistors are switched on (checked by Regloplas)</p>
2	Front panel with two base modules	
3	One option	
4	Several options	

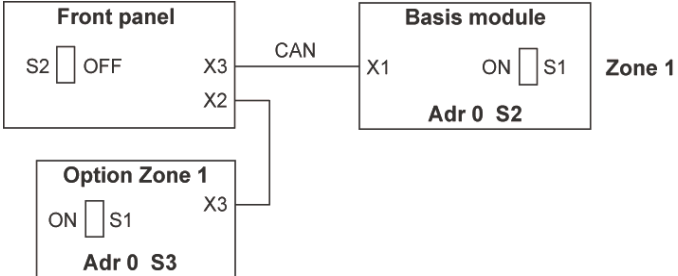
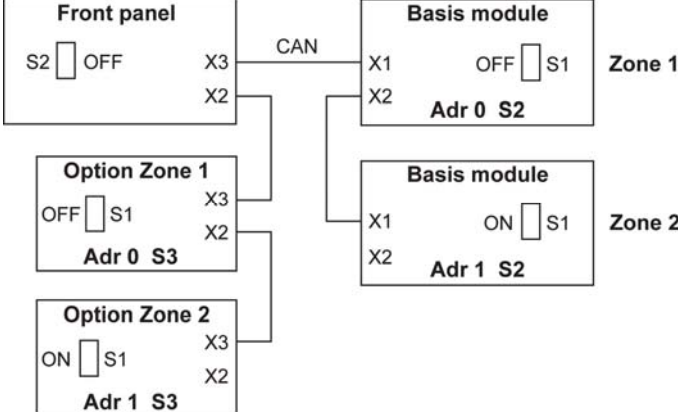
No.	Connection combination	Description
5	Front panel with option	 <p>Front panel: S2 OFF, X3, X2</p> <p>Option Zone 1: ON S1, X3, X2, Adr 0 S3</p> <p>Basis module (Zone 1): X1, X2, ON S1, Adr 0 S2</p> <p>Connection: CAN bus from X1 to X3</p>
6	Front panel with option	 <p>Front panel: S2 OFF, X3, X2</p> <p>Option Zone 1: OFF S1, X3, X2, Adr 0 S3</p> <p>Option Zone 2: ON S1, X3, X2, Adr 1 S3</p> <p>Basis module (Zone 1): X1, X2, OFF S1, Adr 0 S2</p> <p>Basis module (Zone 2): X1, X2, ON S1, Adr 1 S2</p> <p>Connection: CAN bus from X1 to X3</p>

RT100 Control System Parameter Menu Structure

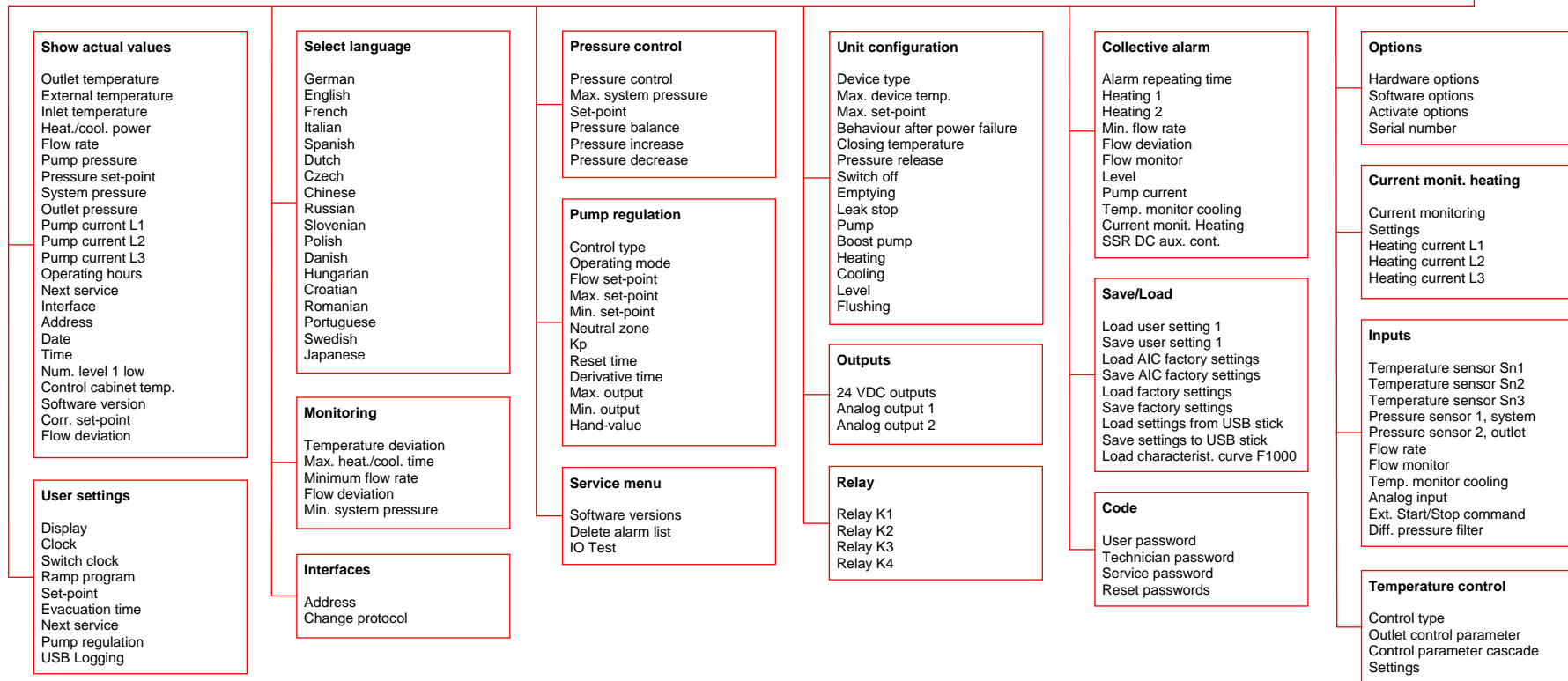
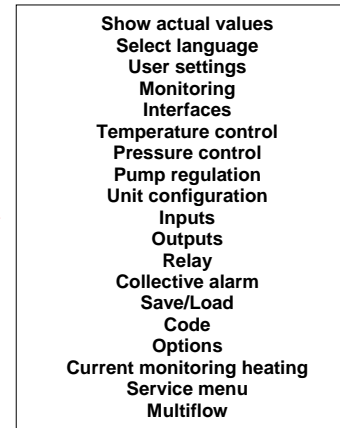

Spare Parts

Ordering Spare Parts

For fast, error-free supply of spares, we need the following data without fail:

- Device type
- Device number
- Voltage
- Frequency

This information is given on the rating plate on the device.

- Position number of the component

This information is given in the corresponding figures in this operating manual (also see the service section) and in the electrical circuit diagram of the device.

CAUTION



Only original Regloplas spare parts may be used!
In case of damage from the use of non-original parts, the warranty will be rendered null and void!

RT100 Control System - Spare Parts

RT Display unit - complete	176-100028
RT100 Base module - 115/230 VAC	176-100001
RT100 Memory print	176-100002
RT100 Digital Option	176-100003
RT100 Analog Option	176-100004
RT100 cable, Universal, L=300 mm, X61 X62	176-100005
RT100 Front panel	176-100006
RT 100 cover for control knob	176-100007
RT100 control knob	176-100008
RT100 Option Reversal of Direction of Rotation >9A	176-100009
RT100 Option Current Monitoring Heating	176-100010
RT100 cable 20 mA CL Aarburg, L=300 mm, X51 X52	176-100011
RT100 Profibus DP	176-100012
RT100 Profinet-IO	176-100040
RT100 Euromap 66	176-100013
Battery for display unit	177-100002
RT100 Protective cover, lockable, for Display RT100	176-100024
Fuse - F100 - 2,5 AF fast-acting	143-042283
Socket, push-in, 2-pin, black, marking 1 2, sensor inputs 24 VDC, 0.5 A	203-100000
Socket, push-in, 3-pin, black, marking 1 2 3, sensor inputs 24 VDC, 0.5 A	203-100001
Socket, push-in, 3-pin, orange, marking NO C NC, AC In/Out, relay 250 VAC, 3 A	203-100002
Terminal strip, tension spring, 2-pin, orange, marking 1 2, AC In/Out, relay 250 VAC, 3 A	203-100003
Terminal strip, tension spring, 3-pin, orange, marking 1 2 3, AC In/Out, relay 250 VAC, 3 A	203-100004
Terminal strip, tension spring, 3-pin, orange, marking 1 2 ground symbol, AC In/Out, relay 250 VAC, 3 A	203-100005
Terminal strip, tension spring, 4-pin, orange, marking 1 2 3 4, AC In/Out, relay 250 VAC, 3 A	203-100006
Socket, push-in, 4-pin, black, marking T1 T2 T3 ground symbol, AC In/Out, motor 600 VAC, 12 A	203-100007
Socket, push-in, 6-pin, black, marking L1 L2 L3 L N ground symbol, AC In/Out, motor 600VAC, 12 A	203-100008
Terminal strip, tension spring, 9-pin, orange	203-100017

