

**ROBWAY**

**Crane Load Instrumentation**

**RHL-1000  
HYDRAULIC GAUGE  
LOAD INDICATOR  
Instruction Manual**

32 WEST THEBARTON ROAD  
THEBARTON, ADELAIDE  
SOUTH AUSTRALIA 5031

TEL. (08) 8238 3500 FAX (08) 8352 1684  
ISD +61 8 8238 3500 ISD +61 8 8352 1684  
[mail@robway.com.au](mailto:mail@robway.com.au) [www.robway.com.au](http://www.robway.com.au)

---

## **Introduction**

This manual provides Installation, Operation and Maintenance instructions for the RHL-1000 Hydraulic-Gauge Load Indicator system.

## **Description**

Each system is designed and calibrated to work on a 90° angle situation. Failure to operate in the situation will cause erroneous readings and could lead to injury.

## **System Capacities**

From 500 to 16,000 lbs.

## **Component Description**

Each system consists of the following components:

- 6" fluid filled gauge assembly with bracket
- Tension type load cell (diaphragm or piston type)
- 50' to 100' double wire braid hydraulic hose

## **Installation**

The load cell is provided with connections at the top to attach to the floor block and at the bottom to attach to the Christmas tree or derrick floor. This angle forms 90° pulling angle. The system is calibrated for this angle and accuracy will be slightly affected if this angle is not true. The sensitivity of the system will not be affected by a light change in angle however.

Once the load cell is attached to the wellhead, the hose must be ran with no kinks or knots back to the truck or gauge location. Prior to use, always make a visual inspection of the hose looking for cuts and leaks.

The system gauge is a 6" fluid filled instrument, which has been calibrated for a 90° angle and for the load cell, which has been included with the system. Always use the same type load cell as the system was supplied with. The gauge also comes complete with a pulsation damper to regulate pointer movement. This damper must be set for sensitivity. This is accomplished by turning the damper stem clockwise until it stops, and then back off two complete turns. If this is too sensitive, turn the knob clockwise until you get the desired sensitivity. If not sensitive enough, turn the knob counter clockwise until the desired sensitivity is reached.

## **System Accuracy**

± 1%

---

## **Maintenance**

The system requires very little maintenance. The following procedures should be followed to assure an accurate, sensitive reading:

Frequently check the fluid load, particularly when pulling heavy loads. (The load gap on the diaphragm type load cells should be approximately 3/8". The gap is the distance between the casing and the power portion of the load plate).

## **Charging System**

The system should be kept full of hydraulic fluid at all times to accurately indicated hoisted weight or load. A quick check for adequate fluid in the system is the gap between the load cell plate and retainer ring (diaphragm type load cells only). The gap should be approximately 3/8".

Remove all weight from the load cell. Make sure that the hydraulic hose is free from all kinks and sharp bends. Remove cap from check valve located on gauge. Close damper completely. Attach hand pump to the check valve (Note: do not tighten swivel completely at this point). Fill hand pump reservoir with instrument fluid. Note: Keep hand pump reservoir at least half-full at all times to avoid introducing air into the system. Operate hand pump plunger slowly to bleed air from pump at check valve. Raise load cell to a position slightly high than indicator. Loosen load cell plug. Pump enough fluid into system to slightly overcharge the system. Loosen pipe plug and bleed the load cell until you achieve the proper gap. Tighten pipe plug back. Remove hand pump, replace and tighten check valve cap. Open damper to desired setting. Unit is ready to be used.

## **Repair**

Repair of the system is limited to replacement of the hose assembly and repair of load cell diaphragm. A fully trained service technician must do any gauge repair, piston type repair or major load cell repair.

Replacement of rubber diaphragm (diaphragm type load cell only)

Remove (3) socket bolts from both the upper and lower bell housings.  
Remove (1) socket head bolt from load plate.  
Remove (12) socket head bolts holding retainer ring to casing.  
Remove retainer ring from casing. There will be hydraulic fluid between diaphragm and casing.  
Remove diaphragm from casing and empty hydraulic fluid.  
Wipe casing and retaining ring of any excess hydraulic fluid and look for any defects in each piece.  
Replace diaphragm in casing and place retaining ring over the diaphragm.  
Replace all socket head bolts in casing assembly and in bell housings.  
Hook hose and gauge back to load cell and charge per charging instructions.

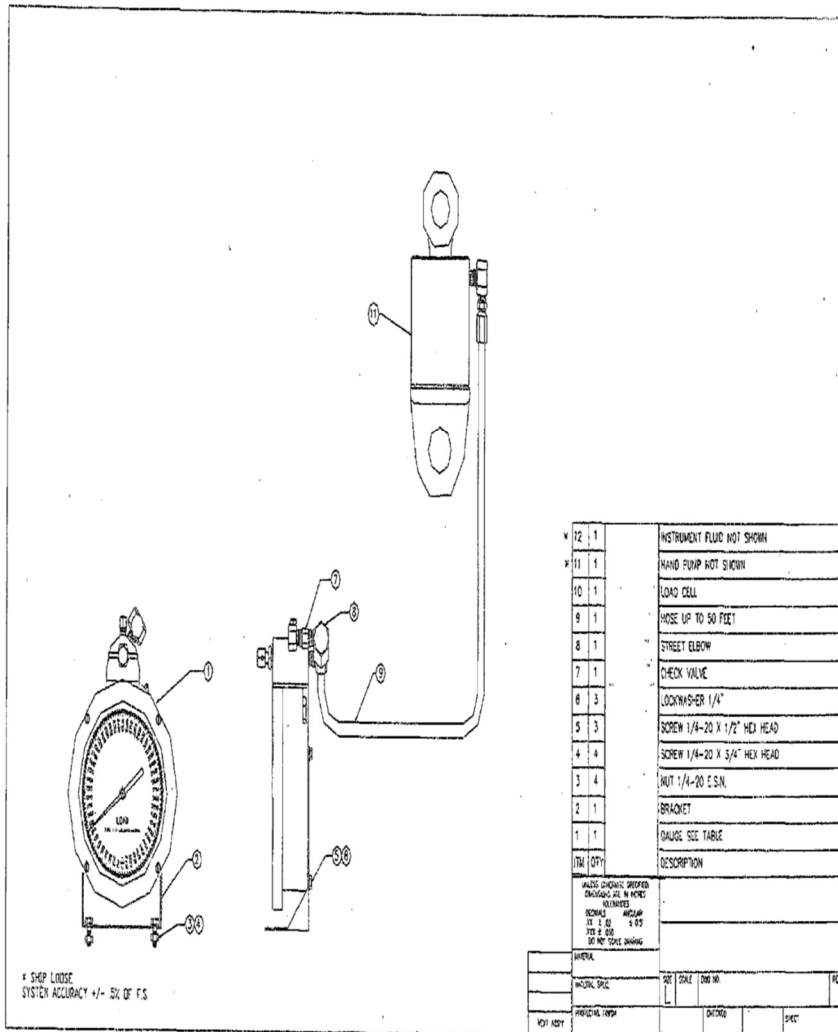

ITEM	QTY	DESCRIPTION
12	1	INSTRUMENT FLUID NOT SHOWN
11	1	HAND PUMP NOT SHOWN
10	1	LOAD CELL
9	1	HOSE UP TO 50 FEET
8	1	STREET ELBOW
7	1	CHECK VALVE
6	3	LOCKWASHER 1/4"
5	3	SCREW 1/8-20 X 1/2" HEX HEAD
4	4	SCREW 1/4-20 X 3/4" HEX HEAD
3	4	NUT 1/4-20 E.S.S.
2	1	BRACKET
1	1	GAUGE SEE TABLE

ALL DIMENSIONS SHOWN  
 UNLESS OTHERWISE SPECIFIED  
 DIMENSIONS ARE IN INCHES  
 DECIMALS ARE TO TWO  
 DIGITS  
 FRACTIONS ARE TO 1/16"  
 DO NOT SCALE DRAWING

REV	DATE	BY	CHKD BY	APP'D
1				

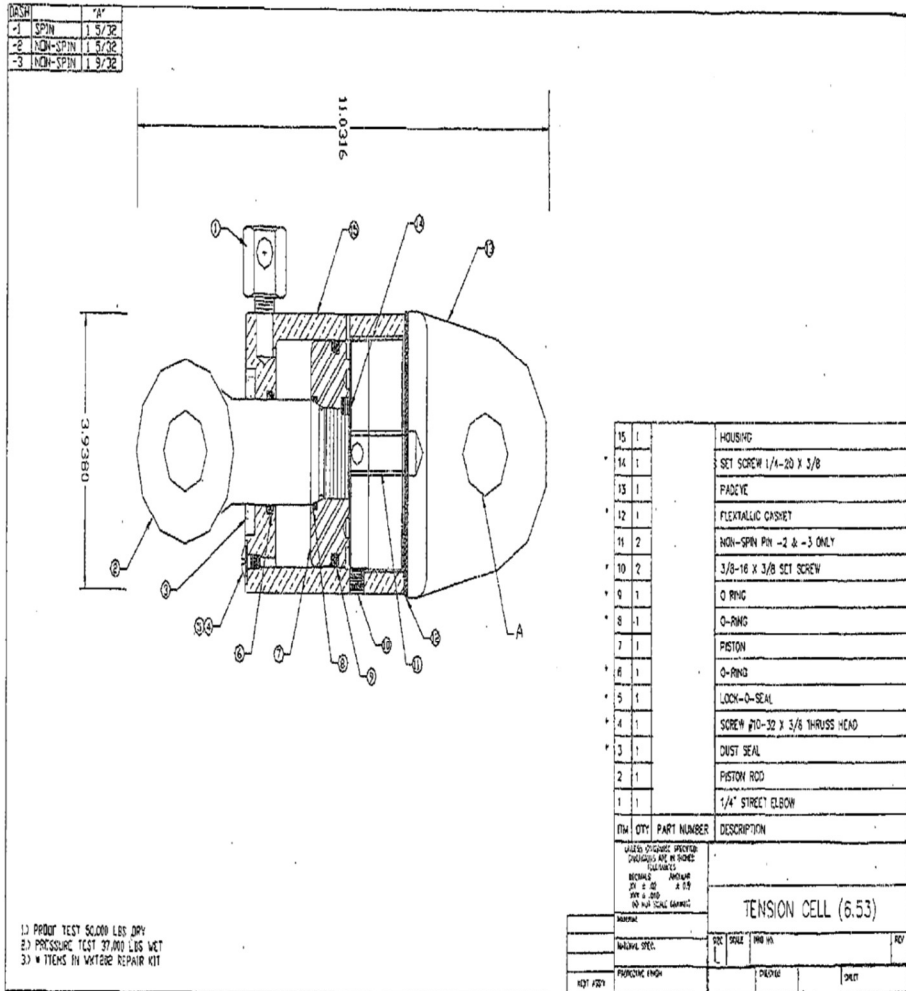

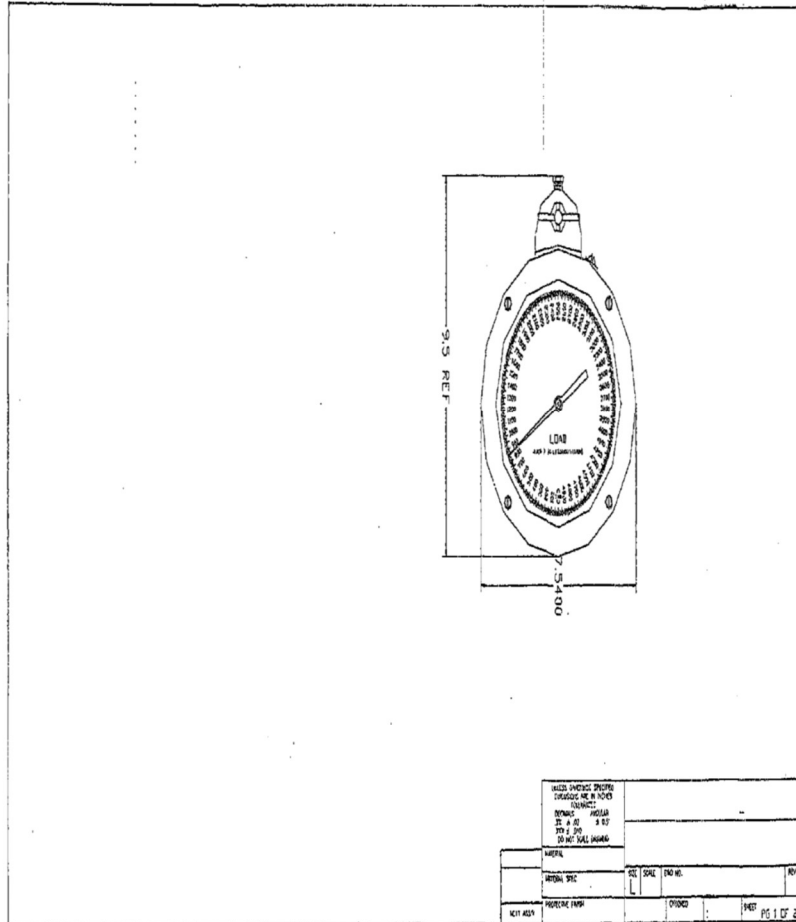

\*\*\* SUBSTITUTE WITHIN FOR PRESSURES OVER 1500 PSI  
 \*\* SUBSTITUTE WITHIN FOR PRESSURES OVER 1500 PSI  
 \* SUBSTITUTE WITHIN FOR PRESSURES OVER 1500 PSI  
 1) PRESSURE TUBE 1200 LB MAX CALIBRATION PRESSURE  
 PRIOR TO CALIBRATION  
 2) CALIBRATION ACCURACY +/- .5% OF F.S.  
 3) SET MAX STOP AT 450 DEGREE

ITEM PART NUMBER	DESCRIPTION	QTY	UNIT
37	1	1	1
36	1	1	1
35	1	1	1
34	1	1	1
33	1	1	1
32	1	1	1
31	1	1	1
30	1	1	1
29	1	1	1
28	1	1	1
27	1	1	1
26	1	1	1
25	1	1	1
24	1	1	1
23	4	1	1
22	1	1	1
21	1	1	1
20	1	1	1
19	1	1	1
18	1	1	1
17	1	1	1
16	1	1	1
15	1	1	1
14	2	1	1
13	1	1	1
12	1	1	1
11	2	1	1
10	2	1	1
9	2	1	1
8	1	1	1
7	1	1	1
6	2	1	1
5	2	1	1
4	1	1	1
3	1	1	1
2	1	1	1
1	1	1	1