

## Safety Switch WZA Operating Instructions

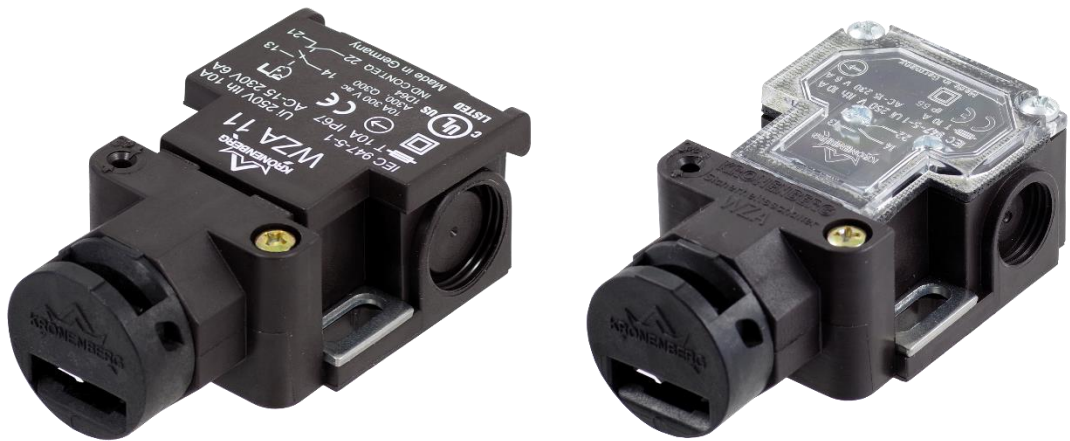

## **Manufacturer**

Hans & Jos. Kronenberg GmbH  
D-51427 Bergisch Gladbach  
Germany

## **Contact**

Hans & Jos. Kronenberg GmbH  
Kurt-Schumacher-Straße 1  
D-51427 Bergisch Gladbach  
Germany

**T:** +49 2204 / 207 -0

**E:** [info@kronenberg-gmbh.de](mailto:info@kronenberg-gmbh.de)

**W:** [kronenberg-gmbh.de](http://kronenberg-gmbh.de)

## **Document Information**

Titel: kro\_ba\_wza\_gb, version of: 15.08.2022

## **Legal Notices**

© Hans & Jos. Kronenberg GmbH

All rights reserved.

All photos are property of Hans & Jos. Kronenberg GmbH.

This documentation may not be copied, modified or translated into any other language in whole or in part.

Especially when using electronic systems, Hans & Jos. Kronenberg GmbH have to agree to processing, duplication or storage of this documentation

**Contents**

**1 General information ..... 4**

1.1 Key words and warning symbols used ..... 4

1.2 Brief description safety switch WZA ..... 5

1.3 Intended use..... 5

**2 Safety ..... 6**

2.1 Safety advice ..... 6

**3 Overview safety switch WZA, actuator and accessories ..... 7**

3.1 Switch - designs..... 7

3.2 Mounting bracket ..... 7

3.3 Actuator - designs ..... 8

**4 Assembly ..... 8**

4.1 Safety switch WZA and actuator ..... 8

4.1.1 Procedure..... 8

4.1.2 Pinned fitting of the switch ..... 9

4.1.3 Specifications for small pivoting radii at standard, tilting or cranked actuators ..... 10

**5 Electrical connection ..... 11**

**6 Functional test ..... 11**

**7 Maintenance, storage, disassembly and disposal ..... 11**

7.1 Maintenance..... 11

7.2 Storage ..... 11

7.3 Disassembly and disposal..... 11

**8 Data sheet ..... 12**

8.1 Dimensions..... 12

8.2 Switch mechanism and circuit diagram ..... 14

8.3 Technical data ..... 15

**9 EU-Declaration of conformity ..... 15**

## 1 General information

In this operating instruction you will find:

- information on installation, adjustment, maintenance and disposal of the assembly WZA
- safety information
- assistance in the case of malfunctions

**Read this operating instruction carefully before you start mounting the device WZA. Pay special attention to the safety instructions, as the failure to comply with them might result in severest injuries, environmental damage or damage to the device and to machines.**

### 1.1 Key words and warning symbols used

**Danger**

Indicates an imminent danger for life and health of persons.

**Warning**

Indicates a potentially dangerous situation. Disregarding this warning may result in death or serious injury. This advice additionally warns of risks for machine, material or environment.

**Attention**

Indicates possible minor personal injury due to neglect.

**Caution**

Indicates possible material damage when disregarding the instructions or gives an important advice for the function.

**Note**

Indicates general information on the handling or the product.

## 1.2 Brief description safety switch WZA

The safety switch WZA has been developed and manufactured in accordance with the applicable national standards and guidelines.

The features of the safety switch at a glance:

---

mechanism:	<ul style="list-style-type: none"><li>• version with hinged lid (WZA10, 11, 11U, 20) or transparent cover (only WZA)</li><li>• mounting brackets made of stainless steel, rotatable to change the hole spacing</li></ul>
electricity:	<ul style="list-style-type: none"><li>• galvanically isolated contact sets</li><li>• positively driven NC contact</li></ul>
actuation:	<ul style="list-style-type: none"><li>• variable revolving drive head</li><li>• as option lateral or frontal actuation</li><li>• actuator is not ejected</li><li>• large tolerance from contact making to the stop of the actuator</li></ul>
mounting points:	<ul style="list-style-type: none"><li>• rotatable movable protection devices as e.g.: protective covers, doors or flaps</li></ul>

---

## 1.3 Intended use

The safety switch WZA is **only** used as intended:

- as component of safety-related functions in installations, machines or lift installations
- in installations that end a dangerous state by opening a rotatable movable protection device
- in combination with the original actuator
- taking into account the information and safety instructions in these operating instructions

The use of the safety switch WZA is only permitted outside Ex-protected areas.

**Any other use** is considered **improper** and may result in personal injury, environmental damage and / or property damage.

Hans & Jos. Kronenberg GmbH do not assume any liability for damages caused by

- improper or incorrect use
- unauthorized repairs or modifications
- use of non-approved spare or accessory parts
- non-observance of this manual

## 2 Safety



**Caution – Read this manual carefully, especially the safety instructions and information on the mounting of the safety switch WZA!**

**For the safety of persons, the environment and to avoid damage to property always observe the country-specific regulations for installation, safety and accident prevention in addition to the safety instructions in this manual.**

- Before mounting familiarize yourself with all functions of the safety switch WZA.
- Keep this manual in a safe and legible condition near the safety switch WZA.
- Only pass the safety switch WZA on to third parties with these operating instructions.

### 2.1 Safety advice



**Danger – Risk of injury or death due to electrical current!**

Only a **qualified electrician** may connect the safety switch WZA to a properly installed power supply line.

When working on the switch make sure that no voltage is applied and protect it against unintentional reconnection.

Operate the switch only with closed or screwed terminal cover.

If the switch housing, the cable gland or the supply cable is damaged the switch may no longer be operated.

Damaged or faulty switches or actuators must not be repaired and must be replaced with original components of the manufacturer.



**Warning – Malfunction and destruction of the safety switch WZA due to incorrect mounting, setup or manipulated actuators**

After mounting the switch and the actuator check that the actuator is accurately fitted into the actuator opening at the switch.

Any change at the actuator, e.g. by mechanical processing such as filing or bending is not allowed.

The spiral pins of the actuators BBA-SL and BBA-U must not be removed.

If pivoting radii are to be observed in the installation, you will find the specifications described in chap. 4.1.3.



**Attention**

Secure the fastening screws at the actuator and the switch with Loctite or alike for protection against self-loosening.

Do not load the switch mechanically and do not use the switch as stop, e.g. as a door stop or flap stop.

Operate the switch only within the permissible temperature range (see chapter 8.3).

Seal the cable entries properly to prevent moisture and dust from entering the switch.

### 3 Overview safety switch WZA, actuator and accessories

The picture below shows the safety switch together with the different actuators.

#### 3.1 Switch - designs

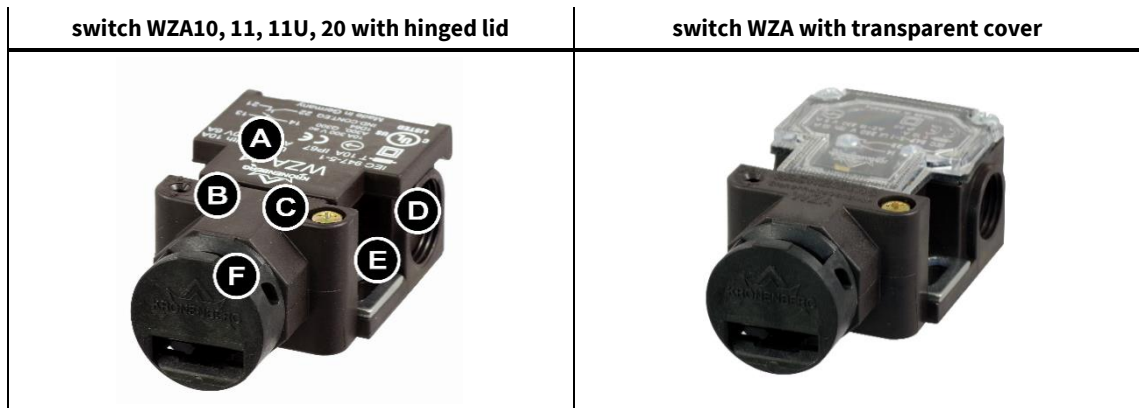

switch-variant:

type*	contacts
WZA10	1 positively driven normally closed contact
WZA11	1 positively driven normally closed contact / 1 normally open contact
WZA11U	1 positively driven normally closed contact / 1 normally open contact
WZA20	2 positively driven normally closed contacts

type*	contacts
WZA	1 positively driven normally closed contact / 1 normally open contact

\* Dimensioning and switching diagrams can be found in chapter 8.

components:

- |                                 |   |
|---------------------------------|---|
| (A) cover switching compartment | (D) cable gland   |
| (B) borehole for pinning        | (E) mounting bracket  |
| (C) fixing screw actuator head  | (F) actuator head<br>(rotatable, 2 insertion openings for actuator) |

#### 3.2 Mounting bracket

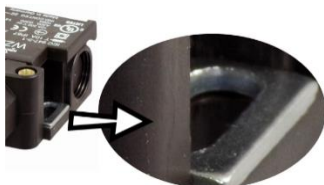

The mounting bracket is removable.

By turning the mounting bracket you can mount the switch on 36 mm or 40 mm hole spacings.

## 3.3 Actuator - designs

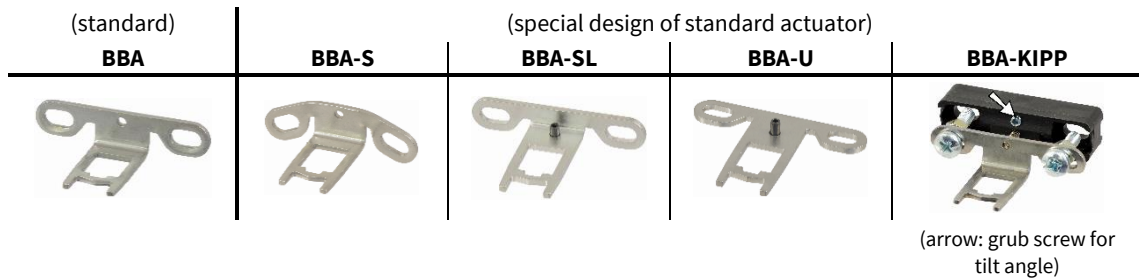

## 4 Assembly



### Note for fixation

You need:

- fixing material\*:
  - screw connections M4 or M5, toothed washers and washers (2 pieces each)
  - countersunk head screws M6 for actuator (2 pieces)
- Loctite or alike for protection against self-loosening of the screw connections

The **switch** can be **mounted in any installation position**.

Ensure that the switch and the actuator are fixed on a full surface base.

\* Please order accessories separately.



### Caution: Installation position of the actuator!

For the installation position of the actuator pay attention to:

- a correct orientation to the switch
- a failure-free insertion of the actuator into the switch

Do not use the actuator as stop.

Pay attention to the specifications for small pivoting radii in chapter 4.1.3.

## 4.1 Safety switch WZA and actuator

### 4.1.1 Procedure

- Determine the installation location for the switch and actuator so that the safety switch WZA can be used as intended.
- Check the distance of the mounting brackets of the switch with the distance of the mounting holes. If the distances are different, you can remove the mounting brackets from the switch, turn and adjust to the 36 mm or 40 mm spacing of the mounting holes. (fig. 4.1a)



fig. 4.1a: remove mounting bracket

continued on next page ...



... continued from previous page

3. Determine the position of the cable gland for the insertion of the cable at the switch.
4. Carefully remove the closing wall at the switch of step 2.  
We recommend to remove the closing wall by screwing in a suitable cable gland.
5. Clean the switching compartment from dirt.
6. Attach the cable gland at the switch. Only use cable glands with the corresponding level of protection.
7. Check the insertion position of the actuator with the position of the actuator head of the switch.
8. If a change of the position of the actuator head is necessary, proceed as follows:
  - a) Loosen the fixing screw on the switch. (fig. 4.1b)



fig. 4.1b: loosen fixing screw

- b) Turn the actuator head at the switch to the requested position.  
The actuator head is infinitely rotatable and engages in 4 preferred positions on the switch.
  - c) Screw in the fixing screw on the switch again (max. torque 1Nm).  
You thus fix the position of the actuator head.
9. Mount the switch.
10. After mounting clean the switch outside and in the switch compartment from dirt.
11. Mount the actuator and observe the notes on the installation position (see chapter 8.2).
12. After installation clean the actuator from dirt.

#### 4.1.2 Pinned fitting of the switch



After mounting and adjusting the actuator you can fix the switch with a pin ( $\varnothing$  3mm) against rotation.

## 4.1.3 Specifications for small pivoting radii at standard, tilting or cranked actuators

standard-actuator:

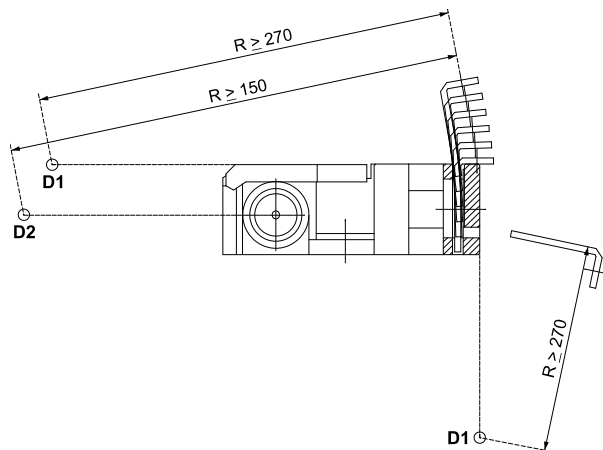

standard-actuator:

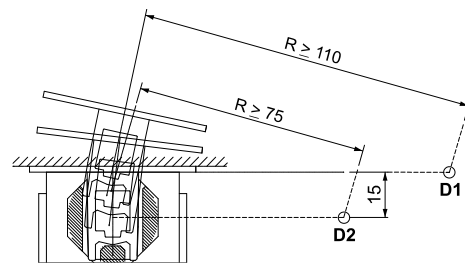

tilting-actuator\*:

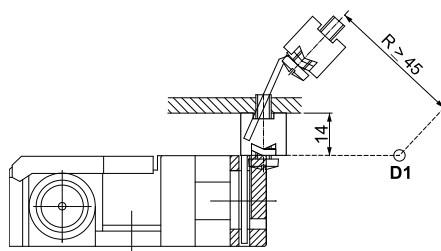

cranked actuator\*:

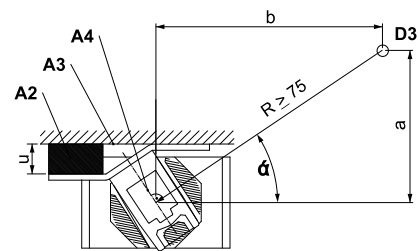

\* reduced pivot radius

**Legend:**

- A2: base cranked actuator
- A3: safety door
- A4: center line of the drive head

- D1: pivot point at the top edge of the switch
- D2: pivot point in the center of the switch
- D3: pivot point above the top edge of the switch
- R: pivoting radius for actuator



**Notes on cranking the actuator**

For special installation positions you can ensure the accurate insertion into the switch by cranking the actuator. For special installation positions please contact the manufacturer for the specifications of cranking the actuator.

Calculation specifications:  $\alpha = \arctan a/b$ ,  $u = 18 \sin \alpha$ ,  $R = a/\sin \alpha$

## 5 Electrical connection



### **Danger – Risk of injury or death due to electric current!**

Only a **qualified electrician** may connect the safety switch WZA to a properly installed power supply line.

The electrical connection must only be made when the power is switched off.

The contacts are marked on the terminal compartment cover and in the terminal compartment at the terminals.

The switching diagrams of the WZA variants are described in chapter 8.2.

Use copper conductors only. Use 60/75 °C conductors only.

Wire range no. 14-18 AWG. Tightening Torque 0.79 lb in.

## 6 Functional test

1. Check the tightness of the switch and actuator.
2. Check the electrical supply for damage.
3. Check the insertion of the electrical supply in the switch for damage and for tightness.
4. Check the correct insertion of the actuator into the switch.
5. Check the switch in **its safety function**.

## 7 Maintenance, storage, disassembly and disposal



### **Danger – Risk of injury or death due to electric current!**

Damaged and faulty switches or actuators must not be repaired. They must be replaced with original components of the manufacturer.

### 7.1 Maintenance

We recommend to perform the tests mentioned in chapter 6 at every maintenance. If necessary remove dust and dirt at the switch and the actuator.

### 7.2 Storage

Store the switch in a clean and dry place. Do not put any loads on the switch.

### 7.3 Disassembly and disposal



### **Danger – Risk of injury or death due to electric current!**

Disassemble only in de-energized state.

Dispose of the components in accordance with national regulations.

## 8 Data sheet

### 8.1 Dimensions

WZA:

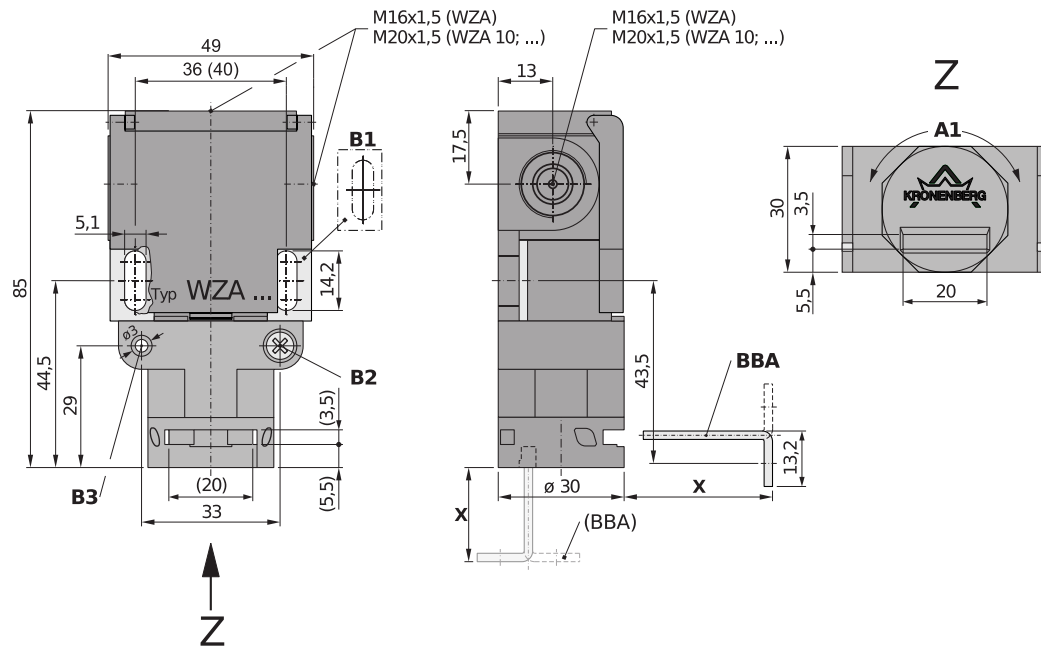

#### Legend:

- A1: head infinitely variable with two insertion openings for actuator
- B1: mounting brackets, rotatable by changing the hole distance
- B2: loosen fixing screw to turn the drive head
- B3: possibility for pinned fitting
- BBA: actuator BBA (accessories – please order separately), other versions available
- X: distance between switch housing and mounting surface for the actuator

## Actuators:

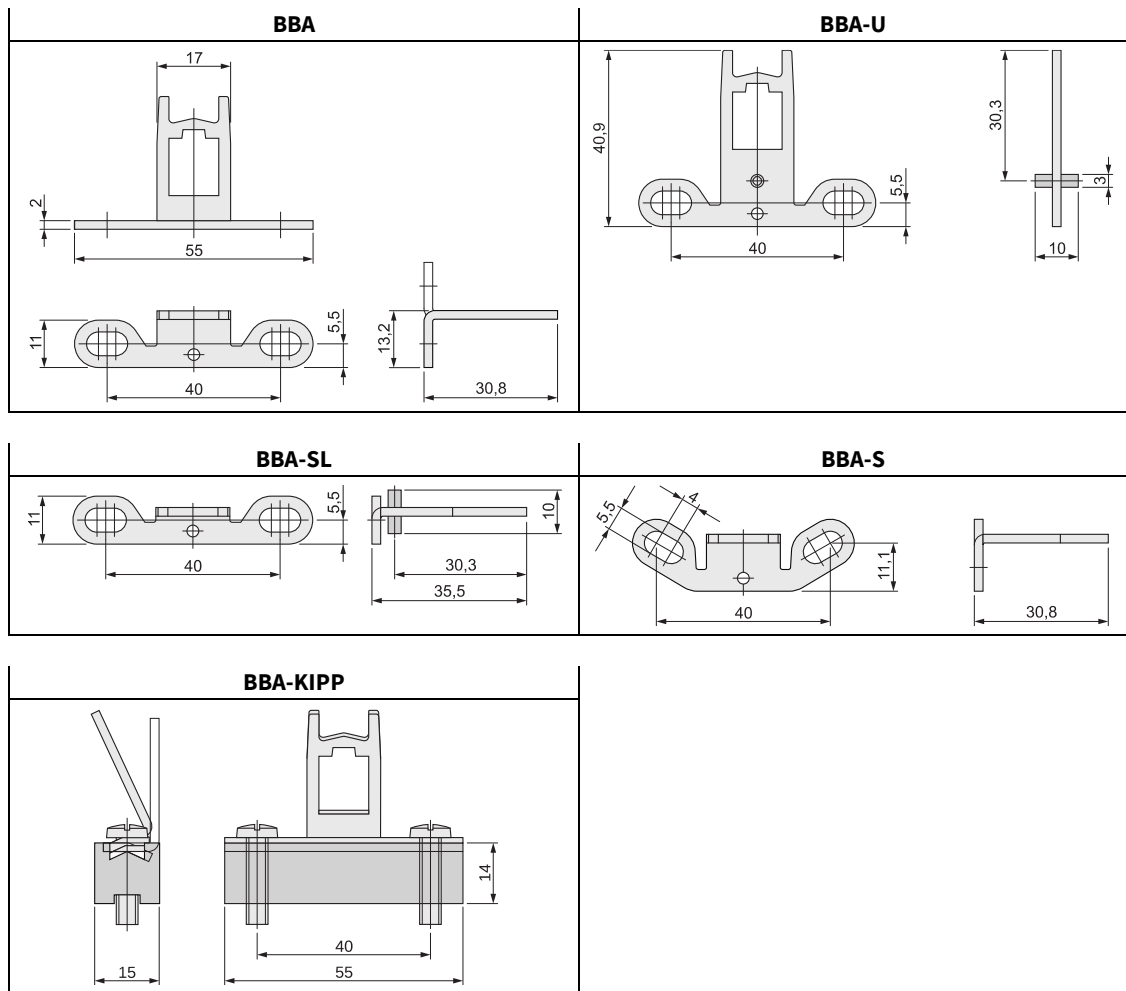

### Legend:

A9: mounting base made of plastics, with pressure spring

## 8.2 Switch mechanism and circuit diagram

The diagrams show the contacts at closed protective device.

### WZA - variants:

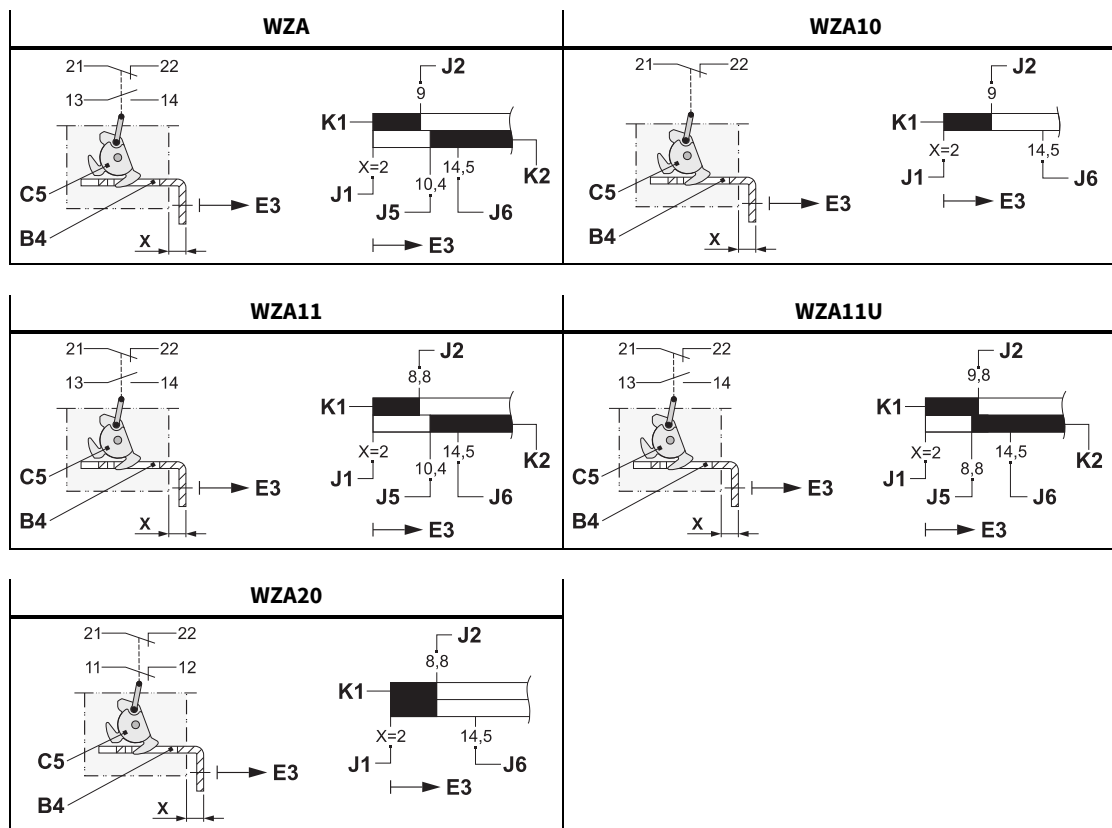

### Legend:

- |   |   |
|---|---|
| B4: actuator  | J6: last contact of actuator and gear drum  |
| C5: gear drum                                       | K1: positively driven normally closed contact is closed, if the actuator is inside the switch |
| E3: pull-out direction actuator                     | K2: normally open- / signal contact is open, if the actuator is inside the switch             |
| J1: maximum depth of immersion (stop)               | X: distance between housing of the switch and mounting surface for actuator                   |
| J2: positively driven normally closed contact opens |   |
| J5: signal contact closes                           |   |

**Switch legend:** ■ contact closed      □ contact open

### 8.3 Technical data

norms	EN 81-20, EN 81-50, IEC/EN 60947-5-1, GS-ET 15, EN ISO 13489-1
switching capacity	Ui = 250 V Ith = 10 A Uimp = 4 kV AC-15: Ue = 230 V Ie = 6 A DC-13: Ue = 200 V Ie = 0,5 A AC-15: Ue = 24 V Ie = 10 A
short-circuit capacity	T 10 A F 16 A
contact material	fine silver
actuation- / back pressure force	9 N / 0 N
connection	by screw terminal max. 2.5 mm <sup>2</sup> cable gland: - 3x M16x1,5 (WZA) - 3x M20x1,5 (WZA10, 11, 11U, 20)
level of protection	IP 66 (WZA), IP 67 (WZA10, 11, 11U, 20)
ambient air temperature	-30 °C up to +80 °C
installation position	any
B10d - value (10% nominal load)	2 million / service life max. 20 years
weight	switch = 87 g actuators = 10 - 30 g

### 9 EU-Declaration of conformity

The current version of the declaration of conformity for the WZA safety switch is available for download on our homepage [www.kronenberg-gmbh.de](http://www.kronenberg-gmbh.de).



## Hans & Jos. Kronenberg GmbH

Kurt-Schumacher-Str. 1 | D-51427 Bergisch Gladbach

T: +49 2204 / 207-0 | E: [info@kronenberg-gmbh.de](mailto:info@kronenberg-gmbh.de)

